

Cartridge check valves type DB, DR

screw-in mounting - from G1/4" to G1/2"

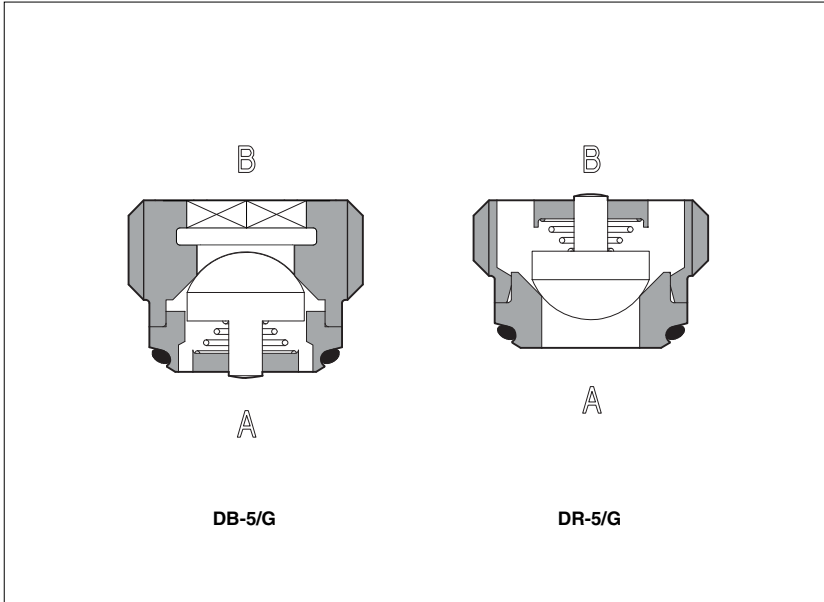

DB, DR are direct operated check valves for screw-in mounting in cavities from G1/4" to G1/2". They are specifically designed to reduce the manifold dimensions and simplify the installation. Cartridge designed to operate in hydraulic systems with hydraulic mineral oil or synthetic fluid having similar lubricating characteristics.

Flow up to 95 l/min.
Pressure up to 350 bar.

1 MODEL CODE

D	B	-	10	/	G	**	/*
Screw-in check valve	B = function A → B R = function B → A				G = Gas threatening	Series number	Synthetic fluid WG = water glycol PE = phosphate ester
Size/threaded connections: 5 = G 1/4" 10 = G 3/8" 15 = G 1/2"							

2 HYDRAULIC CHARACTERISTICS

Hydraulic symbol						
Valve model	DB-5/G	DR-5/G	DB-10/G	DR-10/G	DB-15/G	DR-15/G
Nominal flow (at $\Delta p = 8$ bar)	25	35	55	65	85	95
Max pressure	350					
Cracking pressure	0,3					

3 MAIN CHARACTERISTICS OF CHECK VALVES TYPE DB, DR

Assembly position / location	Any position
Fluid	Hydraulic oil as per DIN 51524 ... 535;
Recommended viscosity	15 ÷ 100 mm ² /s at 40°C (ISO VG 15 ÷ 100)
Fluid contamination class	ISO 19/16, achieved with in line filters at 25 µm value and $\beta_{25} \geq 75$ (recommended)
Fluid temperature	-20°C +60°C (standard and /WG seals) -20°C +80°C (/PE seals)
Flow direction	As shown in the symbol at section 2
Rated flow	See diagrams Q/ Δp at section 4

4 FLOW VERSUS PRESSURE DROP DIAGRAMS based on mineral oil ISO VG 46 at 50°C

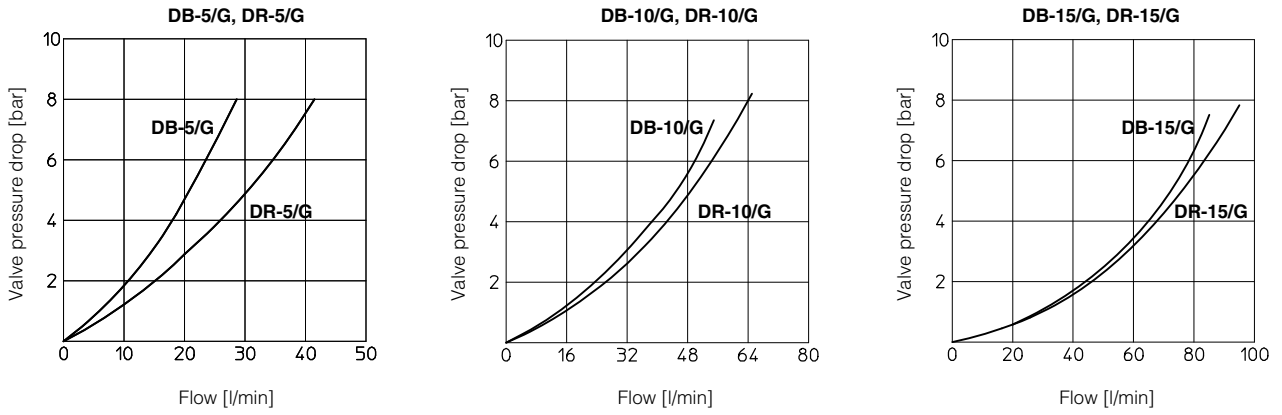

5 RECESS DIMENSIONS [mm]

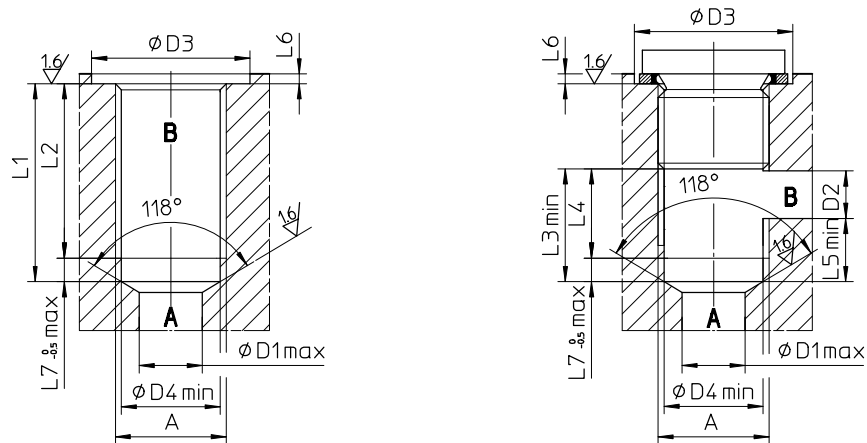

	A	D1	D2	D3	D4	L1	L2	L3	L4	L5	L6	L7
DB-5/G	G 1/4"	8	6	22	11,6	22	19	14	11	8	1,5	3
DR-5/G												
DB-10/G	G 3/8"	9	8	26	15	24	21	17	14	9	1,5	3
DR-10/G												
DB-15/G	G 1/2"	12	12	30	18,75	28	24,5	22	18,5	10	1,5	3,5
DR-15/G												

6 VALVE DIMENSIONS [mm]

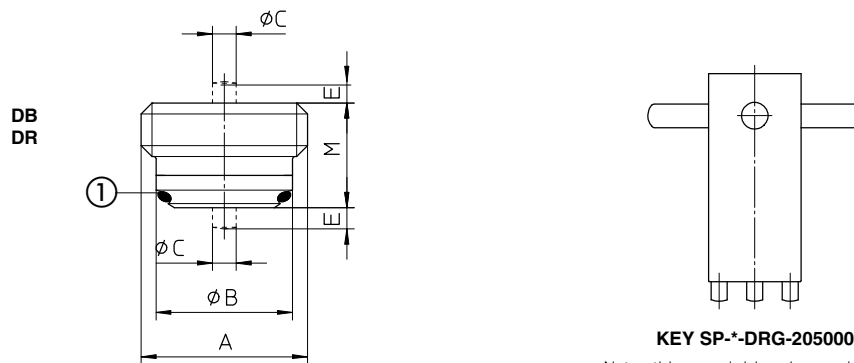

KEY SP-*-DRG-205000

Note: this special key is required for assembling the valve in the cavity

	A	B	C	E	M	①	Mass (Kg)		A	KEY	Tightening torque (Nm)
DB-5/G	G 1/4"	11,5	2,1	1,5	10,3	OR-9x1/70	0,060	DB-5/G	G 1/4"	CH 7	15
DR-5/G			2,4		9					SP-5-DRG-205000	
DB-10/G	G 3/8"	15	2,8	2	11,3	OR-11x1,5/70	0,012	DB-10/G	G 3/8"	CH 7	20
DR-10/G			3,3		2,5					11,4	
DB-15/G	G 1/2"	18,5	3,2	2,5	12,9	OR-14x1,5/70	0,020	DB-15/G	G 1/2"	CH 8	40
DR-15/G			4		2,5					13,6	