

Hydraulic operated directional valves

ISO 4401 size 06, 10, 16, 25 and 32

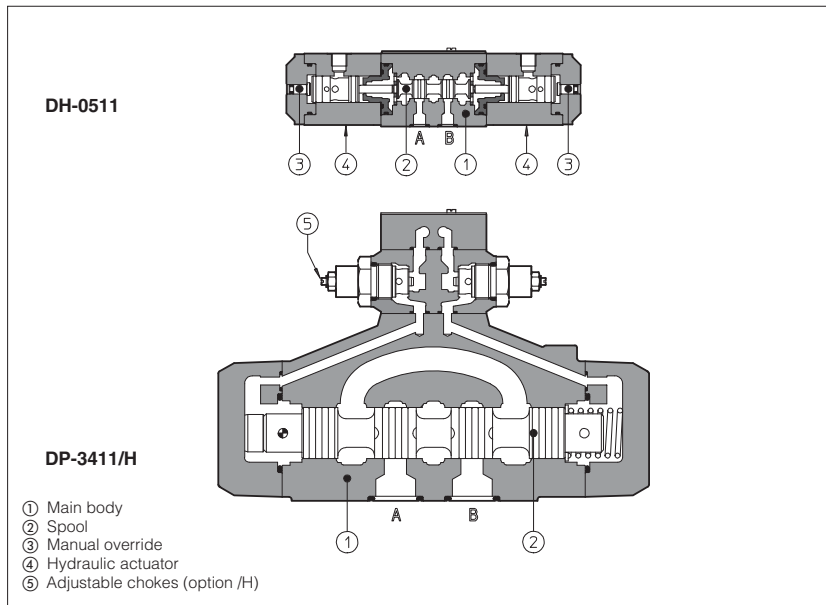

Hydraulic operated directional valves are spool type, three or four way, two or three position, designed to operate in oil hydraulic systems. Available with single or double hydraulic actuator.

- DH-0 = ISO 4401 size 06 interface: flow up to 50 l/min.
- DK-1 = ISO 4401 size 10 interface: flow up to 160 l/min.
- DP-2 = ISO 4401 size 16 interface: flow up to 300 l/min.
- DP-3 = ISO 4401 size 25 interface: flow up to 650 l/min.
- DP-6 = ISO 4401 size 32 interface: flow up to 1000 l/min.

Max pressure:
350 bar for DH-0, DP-2, DP-3, DP-6
315 bar for DK-1

1 MODEL CODE

DH-0	4	1	3	/A	**	/*
Directional control valve, size: DH-0 = 06 DK-1 = 10 DP-2 = 16 DP-3 = 25 DP-6 = 32 Type of actuator: 4 = single actuator 5 = double actuator Valve configuration, see section 4 0 = free, without springs 1 = spring centered, without detent 3 = spring offset external position 5 = 2 external positions, with detent (only for DH and DK) 7 = center and external positions					Synthetic fluids: WG = water-glycol PE = phosphate ester Series number Options: only for DH-04 and DK-14, see section 4: /A = actuator device mounted on side of port B only for DP: /H = adjustable chokes for controlling the main spool shifting time (meter-out to the pilot chambers of the main valve) /H9 = adjustable chokes for controlling the main spool shifting time (meter-in to the pilot chambers of the main valve) /M = hydraulic pressure centering device (only for DP-*51*) /R = with check valve on port P /S = main spool stroke adjustment	
				Spool type, see section 5		

2 HYDRAULIC CHARACTERISTICS



Valve model	DH-0	DK-1	DP-2	DP-3	DP-6
Max recommended flow [l/min]	50	160	300	650	1000
Max pressure on port P, A, B [bar]	350	315	350		
Max pressure on port T (also X, Y for DP) [bar]	see note (1)			250	
Max pressure on port L [bar]	-			null pressure	
Minimum pilot pressure [bar]	3 (min) 5 (suggested)		4 (10 for option /M)		
Max recommended pressure on piloting line [bar]	70			250	
Operation	Acting the actuator on port A, the hydraulic connections are P→B, A→T, except for spool type 4 and 5 where the connections are P→A, B→T.		The spool displacement is achieved by hydraulic pressure on one of the pilot chambers, while the other is unloaded. When pressurizing port X, the port Y has to be directly connected to the tank at null pressure and viceversa. By pressurizing port X, the hydraulic connections are P→B, A→T, except for spool type 4 and 5 where the connections are P→A, B→T. In the spring centered versions the spool is centered by the spring action when both the pilot chambers are unloaded. For valves provided with pressure centering device (option /M), the spool is centered by the simultaneous application of pilot pressure at both X and Y ports: the hydraulic centering device provides different section areas and the spool is actuated into centre position by the resulting hydraulic force. When /M device is fitted, the drain port L has to be connected to tank at null pressure.		

1) The max pressure on port T has to be not over 50% of pilot pressure.

3 MAIN CHARACTERISTICS OF HYDRAULIC OPERATED DIRECTIONAL VALVES



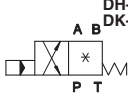
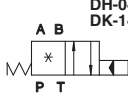

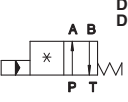
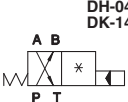
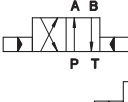
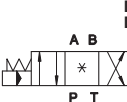
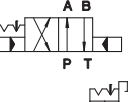
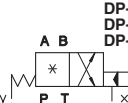
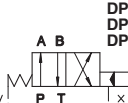
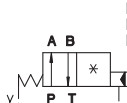
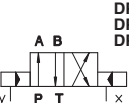
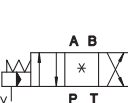







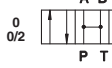



Assembly position / location	Any position except for valves type DH-050, DK-150, DP-*50 (without springs) that must be installed with their longitudinal axis horizontal.
Subplate surface finishing	Roughness index $\sqrt{0.4}$, flatness ratio 0,01/100 (ISO 1101)
Ambient temperature	-20°C to + 70°C
Fluid	Hydraulic oil as per DIN 51524...535, for other fluids see section 11
Recommended viscosity	15 ÷ 100 mm ² /s at 40°C (ISO VG 15 ÷ 100)
Fluid contamination class	ISO 19/16, achieved with in line filters at 25 µm value and β ₂₅ ≥ 75 (recommended)
Fluid temperature	-20°C +60°C (standard and /WG seals) -20°C +80°C (/PE seals)

4 VALVE CONFIGURATION

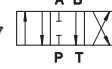
 DH-041* DK-141*	 DH-041*/A DK-141*/A	 DH-043*/2 DK-143*/2	 DH-043*/2/A DK-143*/2/A	 DH-047* DK-147*
 DH-047*/A DK-147*/A	 DH-050*/2 DK-150*/2	 DH-051* DK-151*	 DH-055*/2 DK-155*/2	
 DP-241* DP-341* DP-641*	 DP-243* DP-343* DP-643*	 DP-247* DP-347* DP-647*	 DP-250* DP-350* DP-650*	 DP-251* DP-351* DP-651*

Where the symbol doesn't show the hydraulic connection (*), it depends by the central configuration of the spool, see table 5.

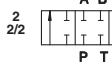
5 SPOOLS - for intermediate passages, see tab. E001

DH-0 DK-1	 0 0/2	 3	 6	DP-2 DP-3 DP-6	 0 0/2	 3	 6
	 1/2	 4	 7		 1/2	 4	 7
	 2 (ONLY DH-0) 2/2	 5	 8		 2/2	 5	 8

NOTES

- Spools type 0 and 3 are also available as 0/1 and 3/1, where in centre position oil passage from ports to tank are restricted;
- Spools type 1,4 and 5 are also available as 1/1, 4/8 and 5/1 (not available for DP-6). They are properly shaped to reduce water-hammer shocks during the switching;
- Spool type 1, 3, 8 and 1/2 for DH-0 and DK-1 are available as 1P, 3P, 8P (only for DH-0), and 1/2P to limit valve leakage.
- On request, other type of spools are available.

6 Q/Δp DIAGRAMS

DH-0	See note and diagrams on table E010 relating the DHO valve from which DH-0* are derived
DK-1	See note and diagrams on table E025 relating the DKE, DKER valve from which DK-1* are derived
DP-2	See note and diagrams on table E080 relating the DPHO-2 valve from which DP-2* are derived
DP-3	See note and diagrams on table E080 relating the DPHO-3 valve from which DP-3* are derived
DP-6	See note and diagrams on table E080 relating the DPHO-6 valve from which DP-6* are derived

7 DIMENSIONS OF HYDRAULIC OPERATED VALVES ISO 4401 size 06 and 10 [mm]

ISO 4401: 2005

Mounting surface: 4401-03-02-0-05

Fastening bolts: 4 socket head screws M5x50 class 12.9

Tightening torque = 8 Nm

Diameter of ports A, B, P, T: $\varnothing = 7,5$ mm (max)

Seals: 4 OR 108

P = PRESSURE PORT

A, B = USE PORT

T = TANK PORT

For the max pressures on ports, see section 2

DH-04**

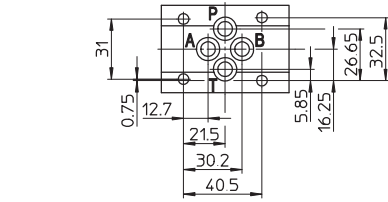

DH-05**

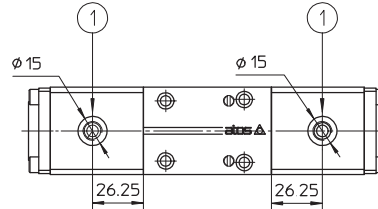
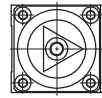
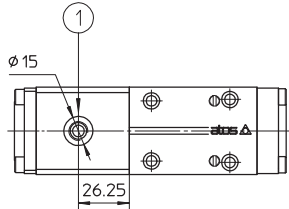
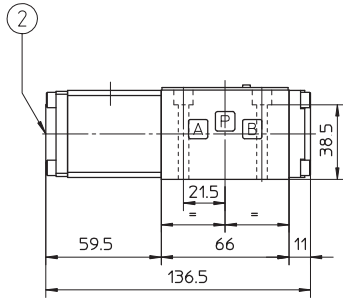
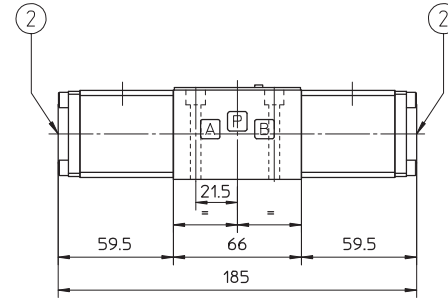

Mass: 1,2 Kg

- ① Pilot pressure port G1/8"
- ② Manual override

Mass: 1,6 Kg

Mounting subplates: see tab. E010

ISO 4401: 2005

Mounting surface: 4401-05-05-0-05

(without X port)

Fastening bolts: 4 socket head screws M6x40 class 12.9

Tightening torque = 15 Nm

Diameter of ports A, B, P, T: $\varnothing = 11,2$ mm (max)

Diameter of port Y: $\varnothing = 5$ mm

Seals: 5 OR 2050, 1 OR 108

P = PRESSURE PORT

A, B = USE PORT

T = TANK PORT

Y = DRAIN PORT

For the max pressures on ports, see section 2

Note: Line Y must be always present and no counter pressure are allowed on this line.

DK-14**

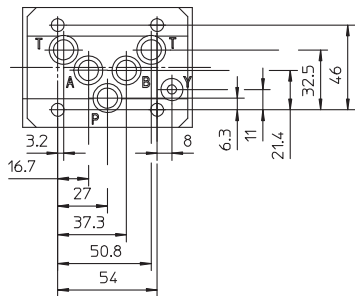

DK-15**

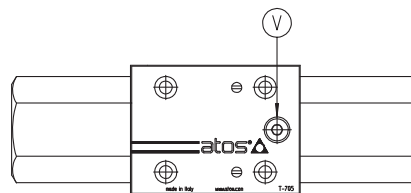
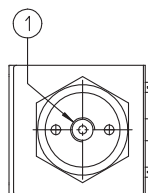
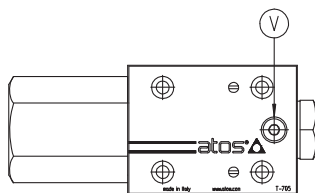
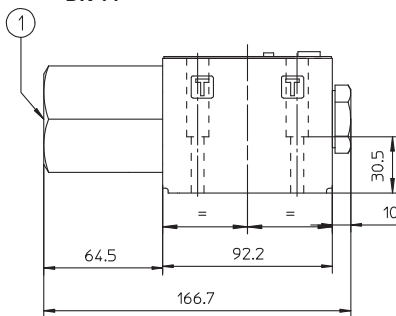
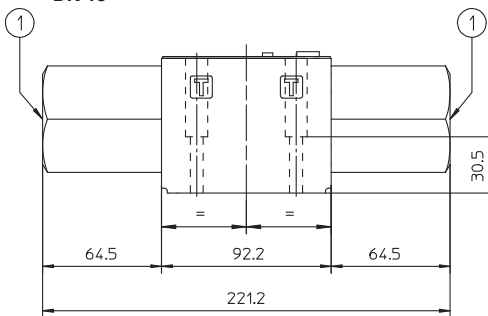

Mass: 3,4 Kg

- ① Pilot pressure port G1/4"
- Ⓥ Air bleed

Mass: 4,2 Kg

Mounting subplates: see tab. E025 (only version /Y)

8 DIMENSIONS OF HYDRAULIC OPERATED VALVES ISO 4401 size 16, 25 and 32 [mm]

DP-2

P = PRESSURE PORT
 A, B = USE PORT
 T = TANK PORT
 X = EXTERNAL OIL PILOT PORT
 Y = DRAIN PORT
 L = DRAIN PORT FOR HYDRAULIC CENTERING DEVICE used only for /M versions
 For the max pressures on ports, see section 2

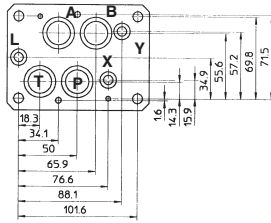

ISO 4401: 2005
Mounting surface: 4401-07-07-0-05
 Fastening bolts:
 4 socket head screws M10x50 class 12.9
 Tightening torque = 70 Nm
 2 socket head screws M6x40 class 12.9
 Tightening torque = 15 Nm
 Diameter of ports A, B, P, T : $\varnothing = 20$
 Diameter of ports X, Y: $\varnothing = 7$ mm
 Diameter of port L: $\varnothing = 5$ mm
 Seals: 4 OR 130, 3 OR 109/70

Stroke adjustment device for option /S

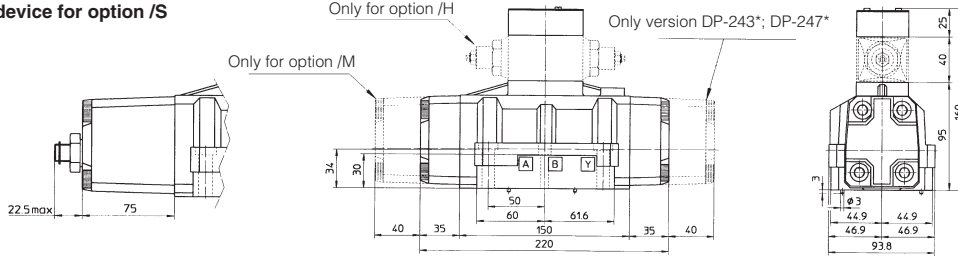

Mass: 10 Kg

Mounting subplates: see tab. E080

DP-3

P = PRESSURE PORT
 A, B = USE PORT
 T = TANK PORT
 X = EXTERNAL OIL PILOT PORT
 Y = DRAIN PORT
 L = DRAIN PORT FOR HYDRAULIC CENTERING DEVICE used only for /M versions
 For the max pressures on ports, see section 2

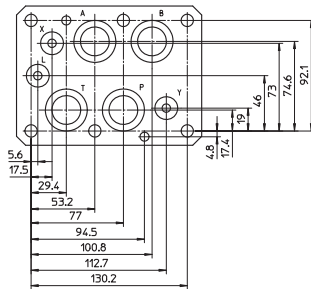

ISO 4401: 2005
Mounting surface: 4401-08-08-0-05
 Fastening bolts:
 6 socket head screws M12x50 class 12.9
 Tightening torque = 125 Nm
 Diameter of ports A, B, P, T : $\varnothing = 24$
 Diameter of ports X, Y: $\varnothing = 7$ mm
 Diameter of port L: $\varnothing = 5$ mm
 Seals: 4 OR 4112, 3 OR 3056

Stroke adjustment device for option /S

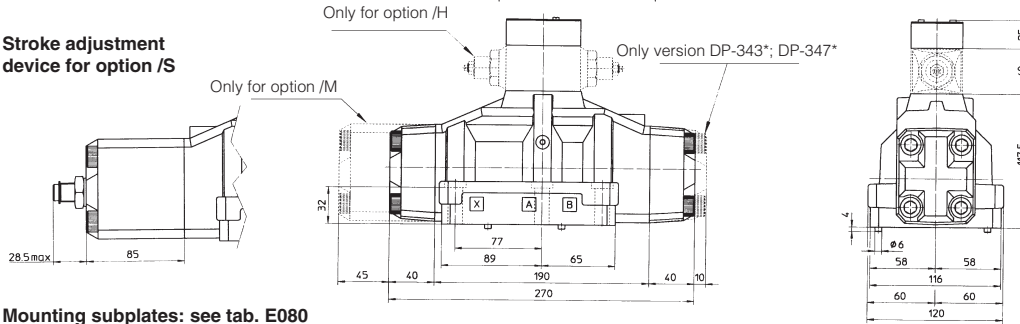

Mass: 15,2 Kg

Mounting subplates: see tab. E080

DP-6

P = PRESSURE PORT
 A, B = USE PORT
 T = TANK PORT
 X = EXTERNAL OIL PILOT PORT
 Y = DRAIN PORT
 L = DRAIN PORT FOR HYDRAULIC CENTERING DEVICE used only for /M versions
 For the max pressures on ports, see section 2

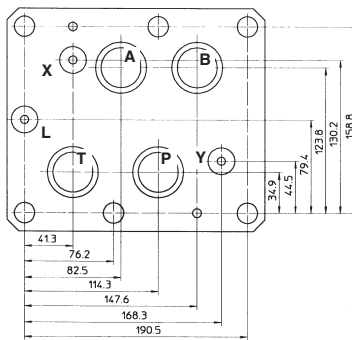

ISO 4401: 2005
Mounting surface: 4401-10-09-0-05 (port L optional)
 Fastening bolts:
 6 socket head screws M20x80 class 12.9
 Tightening torque = 600 Nm
 Diameter of ports A, B, P, T : $\varnothing = 34$ mm
 Diameter of ports X, Y: $\varnothing = 7$ mm
 Diameter of port L: $\varnothing = 5$ mm
 Seals: 4 OR 4137, 3 OR 3081

Stroke adjustment device for option /S

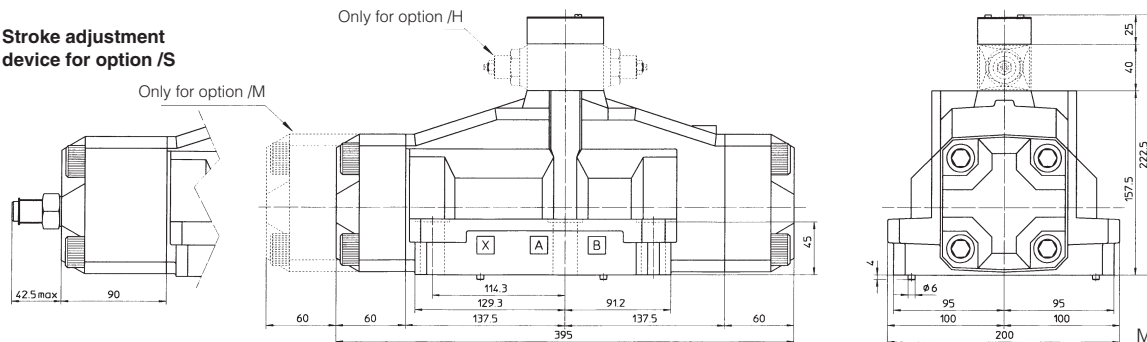

Mass: 38 Kg

Mounting subplates: see tab. K280

When valves are fitted with /M option, mounting subplates /DR are to be used.