

XDC.3... PROPORTIONAL DIRECTIONAL VALVES

CLOSED LOOP POSITION CONTROL



XDC.3...002

PROPORTIONAL SOLENOID	CH. VIII PAGE 9
SE.3.AN21.RS...03	CH. IX PAGE 13
AM.3.H...	CH. VIII PAGE 10
AM.5.H...	CH. VIII PAGE 11
BC.3.07...	CH. VII PAGE 12

The valves XDC serie 2 control the direction and the volume of the flow according to the feeding current to the proportional solenoid. The position transducer type LDVT (inductive position transducer) monitors the actual position of the spool.

In the electronic card (type SE.AN.21.RS...serie 3) the error between the actual position and the reference signal is used to obtain a greater precision of the spool positioning, reducing also considerably the hysteresis and the repeatability error of the valve. For a more accurate flow control, 2 or 3-way pressure compensators modular plate design are available.

The shown flow rates are typical for one line operation (e.g. from P to B). By using the valve with the base for capacity doubling type BC.3.07 greater capacity can be obtained.

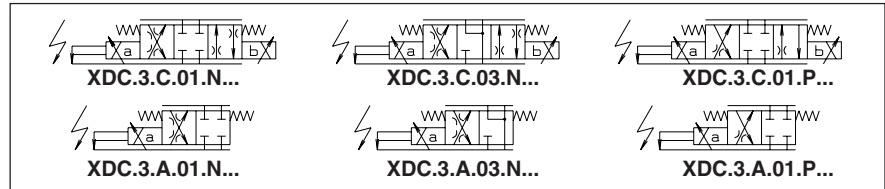

CE Registered mark for industrial environment with reference to the electromagnetic compatibility.

European norms: EN50082-2 - general safety norm - industrial environment;
EN50081-1 -emission general norm - residential environment

ORDERING CODE

XDC	Proportional directional valve with closed loop position control
3	CETOP 3/NG6
*	A = Single solenoid C = Double solenoid
**	Type of spool (null position) 01 = 03 =
*	Flow path control (see hydraulic symbols table) N = symmetrical P = meter in (only with 01 spool)
*	Flow rating l/min (Δp 10 bar) 1 = 8 l/min 2 = 15 l/min 3 = 25 l/min 6 = 40 l/min In order to reduced the unloading pressure for rated flow version at 40 l/min we advise to use the 3 way type AM.5.H.3V... hydrostat.
F	Max. current at solenoid: 1.76 A
00	No variant
2	Serial No.

Notice:
in order to control the valve XDC3...serie 2 it need to use the electronic card SE.AN.21.RS...serie 3, in exclusive way (See Ch. IX).

CONFIGURATION FOR DOUBLE FLOW RATE

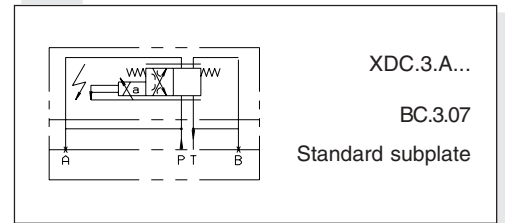

INPUT SIGNAL CURVES - FLOW RATE

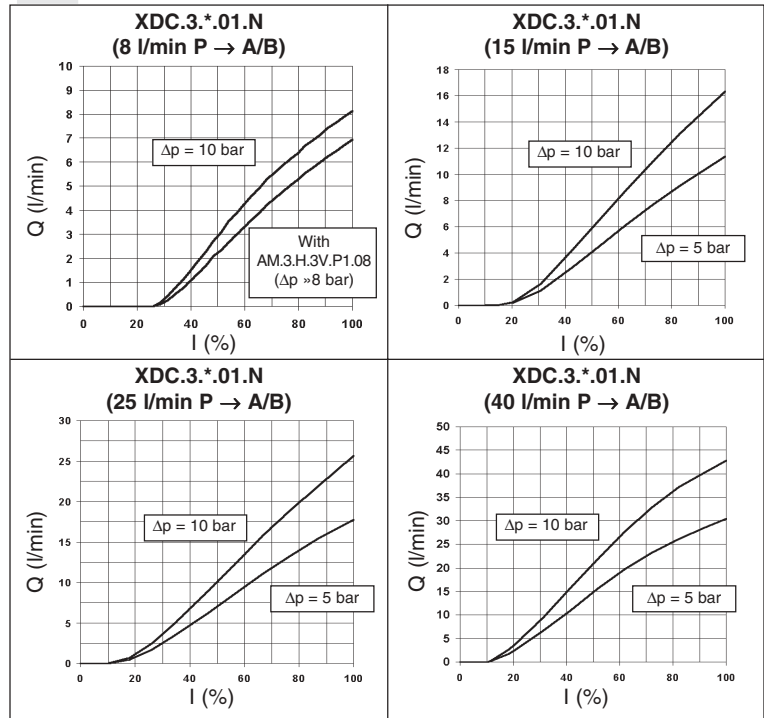

OPERATING SPECIFICATIONS OF VALVE WITH TRANSDUCER

Max. operating pressure ports P/A/B	350 bar
Dynamic pressure port T	210 bar
Static pressure port T	210 bar
Nominal flow	8 / 15 / 25 / 40 l/min
Duty cycle	Continuous 100% ED
Type of protection (depending on the connectors used)	IP 65
Performance curves	See diagrams
Fluid viscosity	10 ÷ 500 mm ² /s
Fluid temperature	-20°C ÷ 75°C
Ambient temperature	-20°C ÷ 70°C
Max. contamination level	class 7 to 9 in accordance to NAS 1638 with filter $\beta_{10} \geq 75$
Weight XDC.3.A... (single solenoid)	1,94 Kg
Weight XDC.3.C... (double solenoid)	2,55 Kg
Max. current	1.76 A
Solenoid coil resistance at 20°C (68°F)	4.55 Ω
Solenoid coil resistance when hot	7.34 Ω
Hysteresis P/A/B/T with pressure compensator AM.3.H.3V...	<1%
Transient function with stepped electrical input signals $\Delta p = 5$ bar (P/A)	
0 ÷ 100%	65 ms
100% ÷ 0	75 ms
Repeatability	<0,5%
Frequency response -3db (Input signal $\pm 25\%$ Vmax)	10 Hz
Insulation class	H
Weight of solenoid	0,6 Kg

Operating specifications are valid for fluids with 46 mm²/s viscosity at 40°C, using the SE3AN21RS... serie 3 ARON electronic control unit.

AMPLIFIER UNIT AND CONTROL

SE.3.AN.21.RS...serie 3 - Electronic card EUROCARD format for control of the proportional valve equipped with transducer

AM.3.H.2V.P1 / AM.3.H.3V.P1
AM.5.H.3V.P1 (*)

Hydrostats 2 or 3 way
(*) for rated flow XDC3 version at 40 l/min) only

TRANSDUCER ELECTRICAL CONNECTIONS

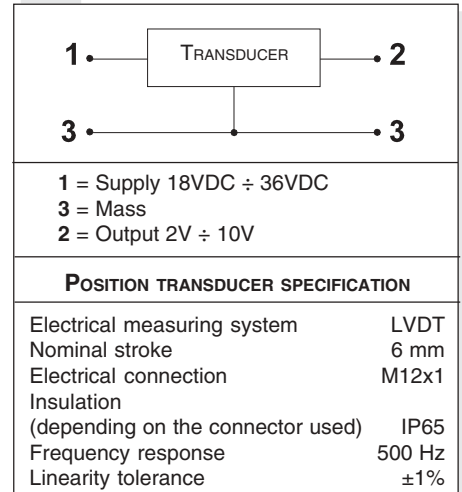

PROPORTIONAL SOLENOID

OVERALL DIMENSIONS

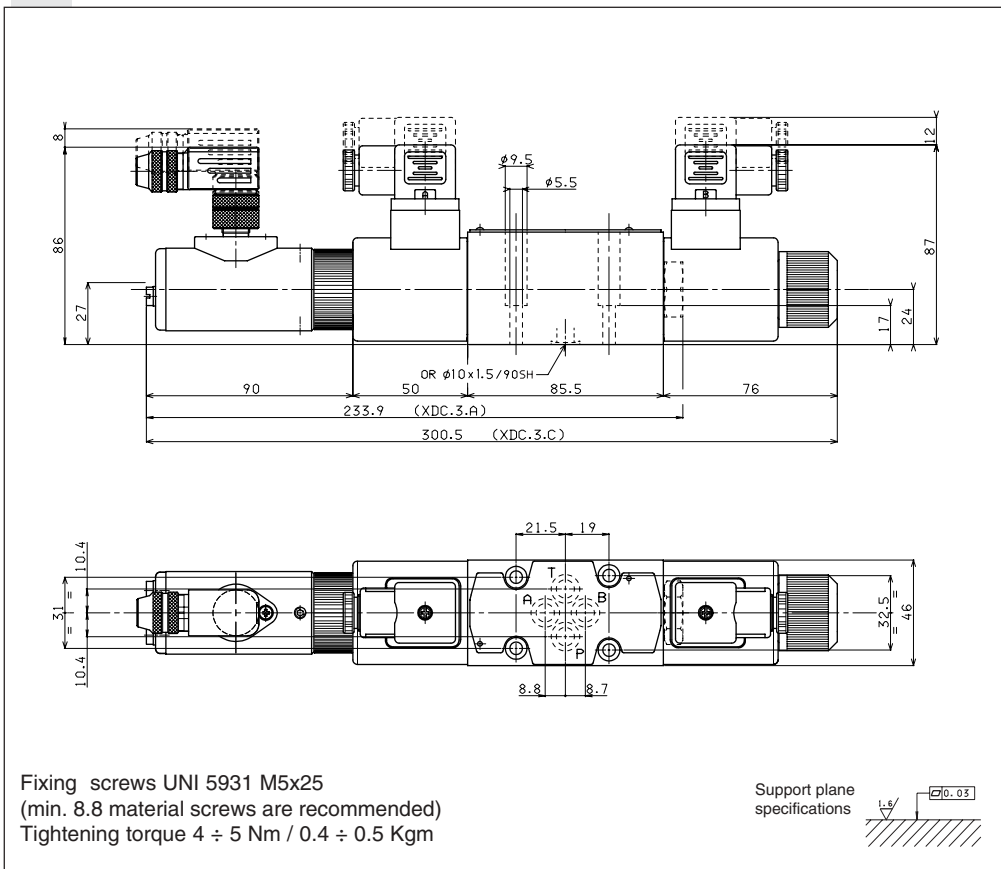

8

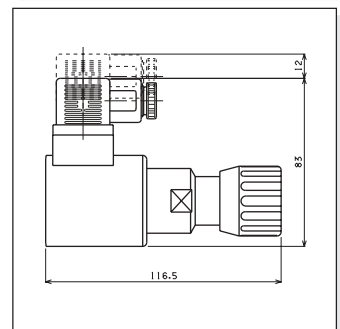
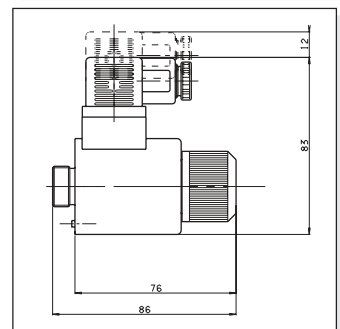

SOL_XDC - 01/2000/e