

ADH.8...4/3 AND 4/2 PILOTED VALVES CETOP 8/NG25

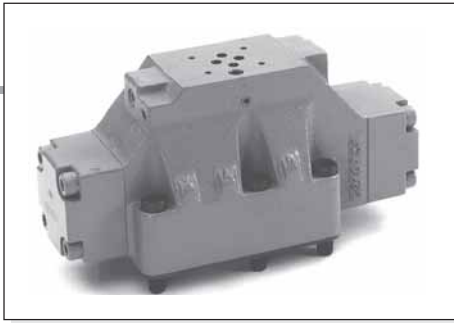

1



Type ADH.8 distributors are intended for interrupting, inserting and diverting a hydraulics system flow.

Normally these distributors are composed of a main stage, crossed by circuit main flow, and of a pilot stage available in several versions.

Various types of controls are available, used either individually or in combination for, among other functions, stroke limitation and main spool movement speed control, in order to optimize the hydraulic system operation where this type of valve is employed.

In those cases where normally to drain spools are used, it is necessary to remember that the minimum changeover pressure due to the opposing springs is equal to approximately 5 bar (see the operating features table next pages) and it is consequently necessary to specify when ordering the check valve incorporated in the P line, if required (as shown below).

- Mounting surface in accordance with UNI ISO 4401 - 08 - 07 - 0 - 94 standard (ex CETOP R 35 H 4.2-4-08).
- Pilot operated spool, solenoid controller.
- Stroke control of main spool.
- Presetting for pressure reducing valve mounting.
- Presetting for single-acting throttle valve mounting.

ADH.8...	
STANDARD SPOOLS FOR ADH.8	CH. I PAGE 58
ADH.8...	CH. I PAGE 59
BSH.7...	CH. I PAGE 60
CETOP 3/NG06	CH. I PAGE 8
STANDARD SPOOLS FOR AD.3.E	CH. I PAGE 10
AD.3.E...	CH. I PAGE 11
D15 DC COIL	CH. I PAGE 18
K12 AC SOLENOID	CH. I PAGE 18
STANDARD CONNECTORS	CH. I PAGE 19

ORDERING CODE

ADH	Piloted valve (Pilot valves and any modulating valves should be ordered separately)
8	CETOP 8/NG25
*	Mounting type (see next page)
**	Spool type (see next page)
*	Piloting and draining I = X internal / Y internal IE = X internal / Y external EI = X external / Y internal E = X external / Y external (see Tab.1 at side)
R	Check valve incorporated at port P - setting 5 bar (Tab. 2 below) Only for I, IE versions (Omit if not required)
**	00 = No variant LC = Main spool stroke limiter
1	Serial No.

TAB. 2 - INTERNAL CHECK ON P

• For the spools 02-04-14-28 the piloting is normally external; the internal piloting is possible with the internal check valve (R).

TAB. 1 - PLUGS ARRANGEMENT FOR THE PILOT AND DRAIN LINES

Plugs type used: M6x6 both for pilot and drain

	ADH.8...I X internal piloting Y internal draining	
	ADH.8...IE X internal piloting Y external draining	
	ADH.8...EI X external piloting Y internal draining	
	ADH.8...E X external piloting Y external draining	

1

PRESSURE DROPS

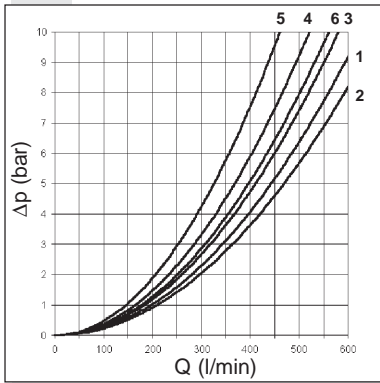

The diagram shows the pressure drops in relation to spools adopted for normal usage (see table). The fluid used was a mineral based oil with a viscosity of 35 mm²/s a 50° C.

Spool type		Connections				
		P→A	P→B	A→T	B→T	P→T
01	ENERGIZING	1	1	2	3	
02	DE-ENERGIZ. ENERGIZING	2	2	1	2	6 ⁽¹⁾
03	DE-ENERGIZ. ENERGIZING	1	1	4 ⁽²⁾ 1	4 ⁽²⁾ 2	
04	DE-ENERGIZ. ENERGIZING	6	6	3	4	5
05	DE-ENERGIZ. ENERGIZING	4 ⁽²⁾ 2	4 ⁽²⁾ 2	2	3	
66	DE-ENERGIZ. ENERGIZING	1	1	2	2	
10	ENERGIZING	1	1	2	3	
14	DE-ENERGIZ. ENERGIZING	6	6	3	4	5 ⁽²⁾
28	DE-ENERGIZ. ENERGIZING	6	6	4	3	5 ⁽²⁾
23	DE-ENERGIZ. ENERGIZING	1	4 2	2	3	
Curve No.						
Notes: (1) A/B stopped - (2) B stopped - (3) A stopped						

SPOOLS AND MOUNTING TYPE

(* Spools with price increasing)

(*) For the E mounting the locating spring works only with the steady system

	C mounting	A mounting	B mounting	E mounting	P mounting
Pilot Piloted	AD.3.E.03.C... ADH.8.C...	AD.3.E.03.E... ADH.8.A...	AD.3.E.03.F... ADH.8.B...	AD.3.E.16.E... ADH.8.E...	AD3E16E/AD3E16F ADH.8.P...
Scheme					
Spool type					
01					
02					
03					
04*					
05					
66					
10*					
14*					
28*					
23*					

PILOT SOLENOID CONTROL VALVE SPECIFICATION

FOR DIFFERENT CONTROLS, PLEASE CONTACT OUR TECHNICAL ARON SERVICE

Max. operating pressure ports P/A/B	320 bar
Max. operating pressure port T (int. drainage)	160 bar
Max. operating pressure port T (ext. drainage)	250 bar
Max. piloting pressure	210 bar
Min. piloting pressure	5 bar
Max. flow with 04-14-28 spools	500 l/min a 210 bar
	450 l/min a 320 bar
Max. flow with all other spools	600 l/min a 210 bar
	500 l/min a 320 bar
Piloting oil volume for engagement 3 position valves	11.1 cm ³
Piloting oil volume for engagement 2 position valves	22.12 cm ³
Hydraulic fluid	mineral oil DIN 51524
Fluid viscosity	2.8 ÷ 380 mm ² /s
Fluid temperature	-20°C ÷ 70°C
Ambient temperature	-20°C ÷ 50°C
Max. contamination level	class 10 in accordance with NAS 1638 with filter $\beta_{25} \geq 75$
Weight ADH8 without pilot valve	13,1 Kg
Weight ADH8 with pilot valve with 1 AC solenoid	14,3 Kg
Weight ADH8 with pilot valve with 1 DC solenoid	14,5 Kg
Weight ADH8 with pilot valve with 2 AC solenoids	14,6 Kg
Weight ADH8 with pilot valve with 2 DC solenoids	15,1 Kg

Switching time

Such values refer to a solenoid valve with P = 100 bar pressure using a mineral oil at 50°C with 36 mm²/sec viscosity PA and BT connections.

SWITCHING TIMES PILOTED VALVE

Solenoids	ENERGIZING ±10% (ms)		DE-ENERGIZING ±10% (ms)	
	2 posit.	3 posit.	2 posit.	3 posit.
AC	60	45	90	60
DC	75	55	90	60

OVERALL DIMENSIONS

CETOP 8 MOUNTING SURFACE

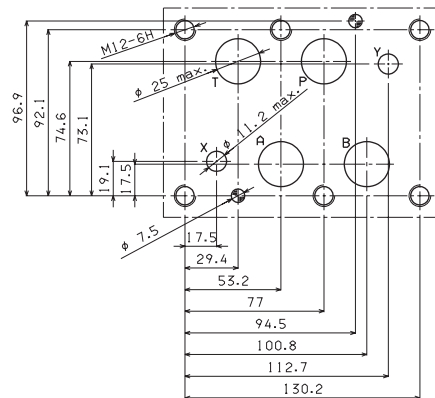
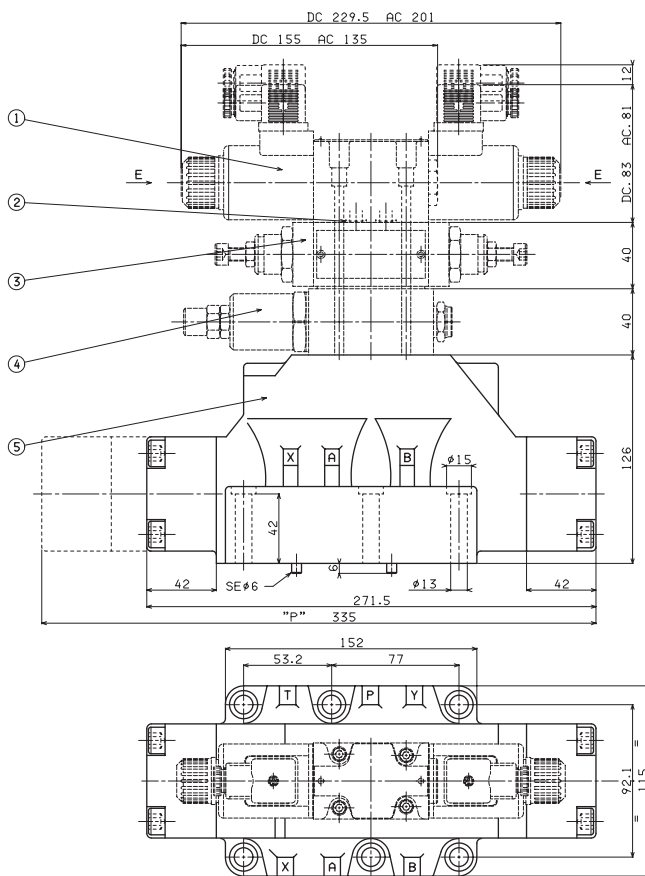

- Piloted valve fixing: n° 6 screws T.C.E.I. M12x60
- Tightening torque: 69 Nm
- Seals: n° 4 OR 2-123 PARKER (type 3118)
n° 2 OR 2-117 PARKER (type 3081)

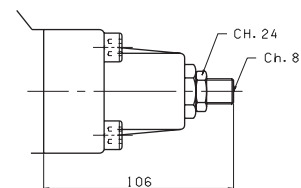

SPOOL STROKE ADJUSTMENT

- 1 Piloted solenoid valve type AD3E... CETOP 3/NG6
- 2 Calibrated diaphragms AD3E...
- 3 Flow regulation valve type AM3QF..C
- 4 Pressure reduction valve type AM3RD..C
- 5 Main valve type ADH7..E

1

BSH.8.13 WITH P, T AND A, B REAR 1" BSP

- BSH** Single plate for piloted valve
- 8** CETOP 8/NG25
- 13** 1" BSP rear connectors
- 00** No variant
- 1** Serial No.

Weight: 6,3 Kg - Fixing screws M10x60 UNI 5931

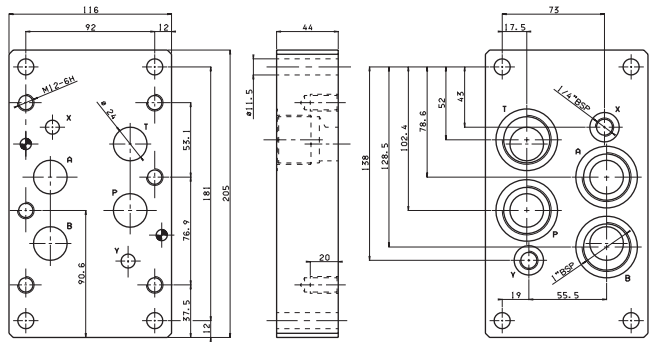

BSH.8.13* WITH P, T AND A, B REAR 1" 1/4 BSP OR 1" 1/2 BSP

- BSH** Single plate for piloted valve
- 8** CETOP 8/NG25
- 13*** **A** = 1" 1/4 BSP rear connectors
B = 1" 1/2 BSP rear connectors
- 00** No variant
- 1** Serial No.

Weight: 21,7 Kg (BSH.8.13A) - Weight: 21,2 Kg (BSH.8.13B)
Fixing screws M12x100 UNI 5931

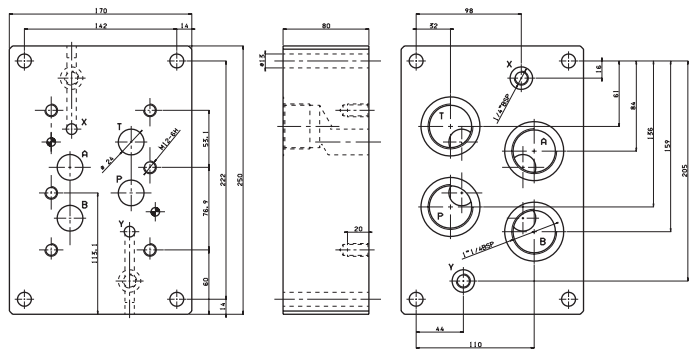

BSH.8.15 WITH T, P AND A, B SIDE 1" BSP

- BSH** Single plate for piloted valve
- 8** CETOP 8/NG25
- 15** 1" BSP side connectors
- 00** No variant
- 1** Serial No.

Weight: 8,2 Kg
Fixing screws M10x75 UNI 5931

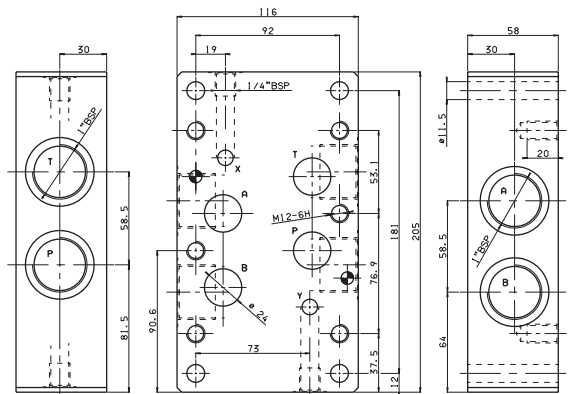

BSH.8.17 WITH P AND T REAR, A AND B SIDE 1" BSP, X AND Y REAR

- BSH** Single plate for piloted valve
- 8** CETOP 8/NG25
- 17** 1" BSP rear and side connectors
- 00** No variant
- 1** Serial No.

Weight: 8,3 Kg - Fixing screws M10x75 UNI 5931

