

FHF 320

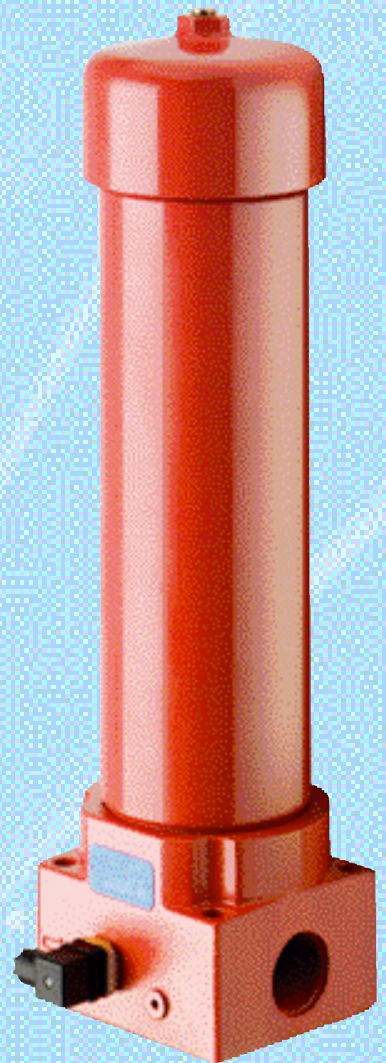

FHF **SERIES** **320**

Working pressure
350 bar

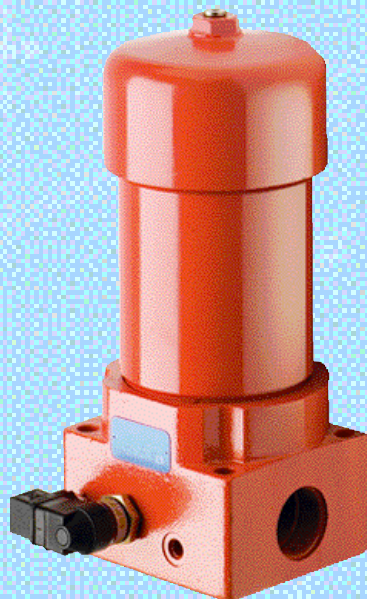
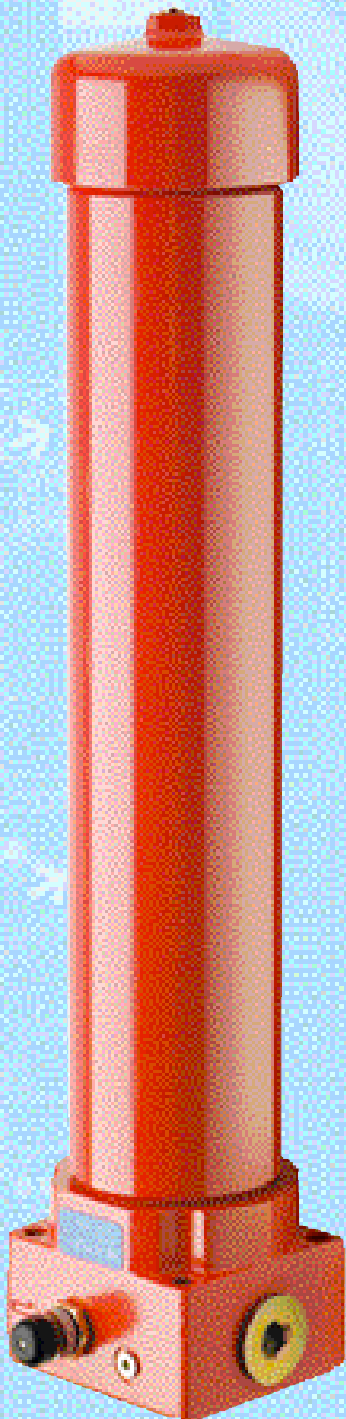
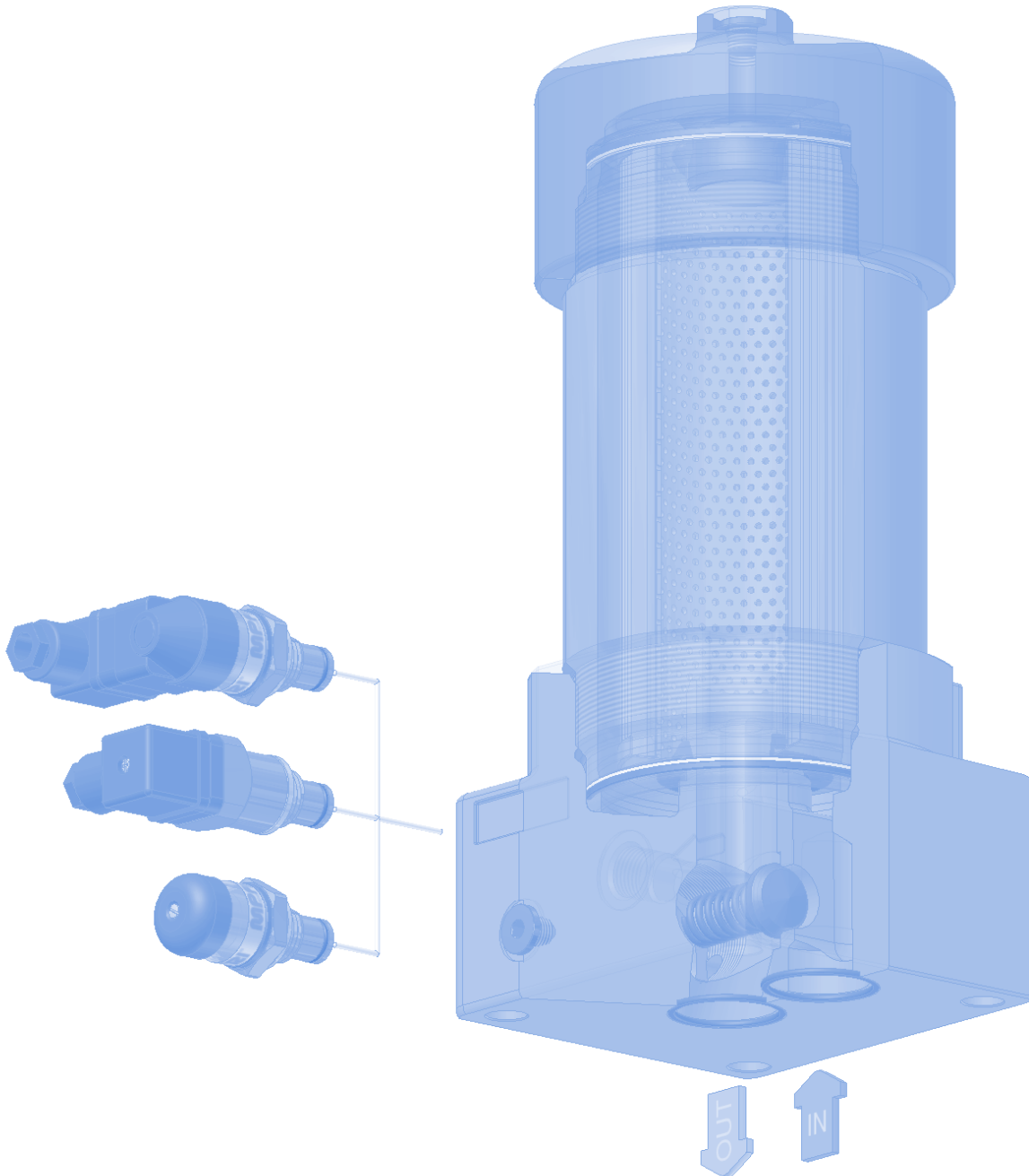

Style S

Style B

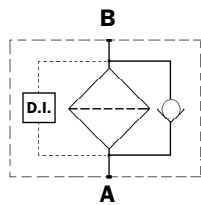
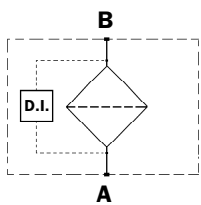

Technical data

Filter body (Materials)

- Head: Cast iron (chemical heat treatment)
- Housing: Steel (chemical heat treatment)
- Bypass valve: Steel
- Check valve: Steel

Pressure

- Maximum operating pressure: 350 bar (35 MPa)
- Test pressure: 525 bar (52.5 MPa)
- Burst pressure: 1260 bar (126 MPa)
- Pulsed pressure fatigue test 1,000,000 cycles with pressure from 0 to 350 bar (35 MPa)

Temperature

- From -25°C to +110°C

Bypass valve

- Opening pressure 6 bar $\pm 10\%$
- Other opening pressures on request.

Elements type Δp

- Elements in micro fibre series N : 20 bar
- Elements in micro fibre series H : 210 bar
- Elements in stainless steel mesh series N : 20 bar
- Oil flow from exterior to interior.

Seals

- Standard Nitrile (NBR) series A
- Optional FPM series V

Weights without filter elements (kg)

Length	1	2	3
• FHF 320	19	35.5	44.5

Filter internal volumes (dm³)

Length	1	2	3
• FHF 320	3.44	5.61	7.75

Connections

In-line Inlet/Outlet
Manifold Inlet/Outlet

Compatibility

- Bodies compatible with:
Mineral oils to ISO 2943 - aqueous emulsions
synthetic fluids, water/glycol.
- Filter elements compatible with:
Mineral oils to ISO 2943 - aqueous emulsions
synthetic fluids, water/glycol.
- Nitrile (NBR) seals series A, compatible with:
Mineral oils to ISO 2943 - aqueous emulsions
synthetic fluids, water/glycol.
- V series FPM seals, compatible with:
Synthetic fluids type HS-HFDR-HFDS-HFDU

Filter Element Area

Filter element in stainless steel mesh
Length

Type	1	2	3
HF320	4150	8050	12250
Values expressed in cm ²			

Pressure drops Δp Housing

The curves are plotted using mineral oil with density of 0.86 kg/dm³ to ISO 3968.

Δp varies proportional with density.

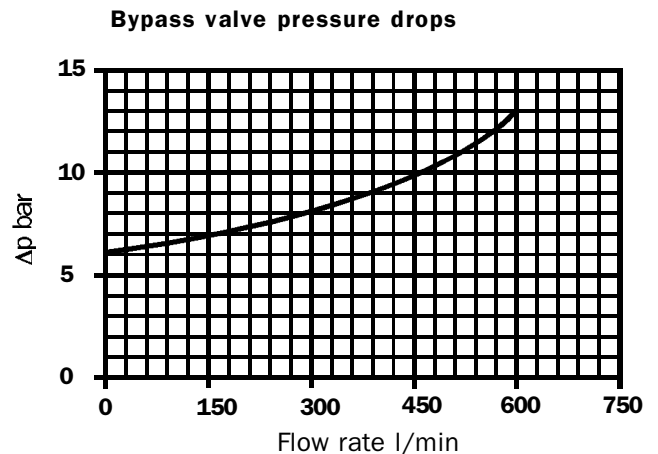
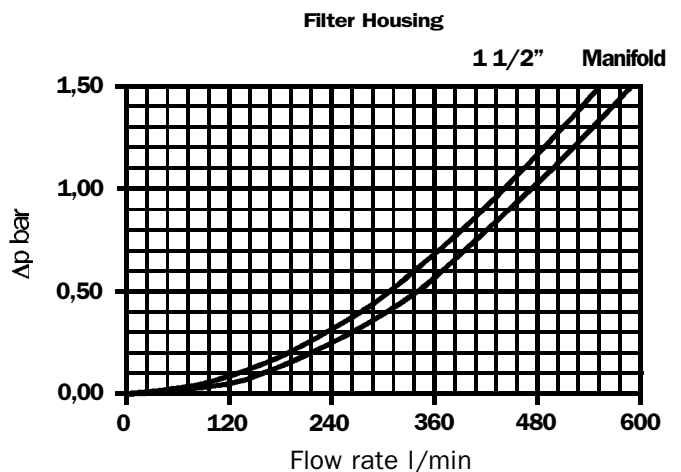

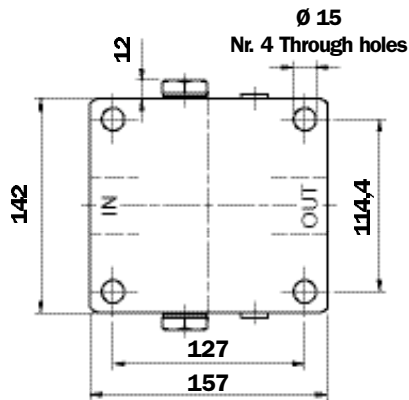
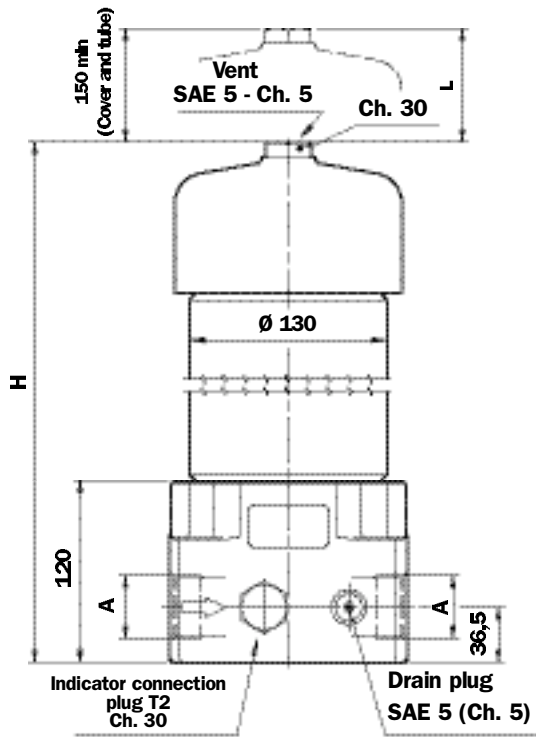

Manifold version

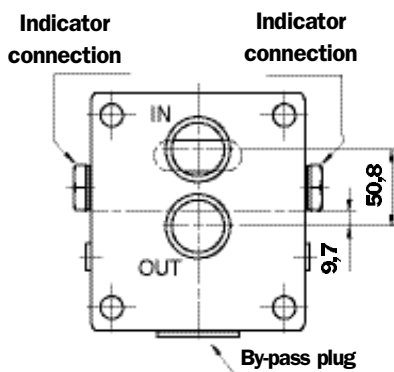
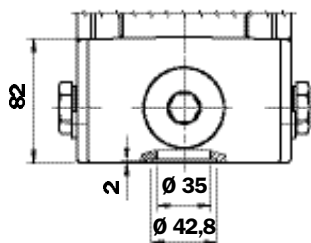

Recommended maximum flow rate

- Pressure drop of complete filter equal to Δp 1.5 bar.
- Oil kinematic viscosity 30 mm²/s (cSt).
- Density 0.86 kg/dm³.
- Connections of filter under test to Manifold.

Filter element type	Flow rate l/min Series N	Flow rate l/min Series H	Filter Length
A03	295	200	1
A06	335	205	
A10	348	280	
A16	400	300	
A25	465	340	
M25	-	-	
A03	380	310	2
A06	400	330	
A10	405	365	
A16	425	380	
A25	485	400	
M25	-	-	
A03	390	350	3
A06	420	355	
A10	425	400	
A16	445	405	
A25	500	420	
M25	-	-	

Filter Length	H mm	L mm
1	368	230
2	603	470
3	843	710

A Threaded Connections	A Flanged Connections
G 1 1/2"	MANIFOLD
1 1/2" NPT	1 1/2" SAE 6000 psi/M
SAE 24 (1 7/8"-12 UN)	
SAE 20 (1 5/8"-12 UN)	1 1/2" SAE 6000 psi/UNC

Spare parts FHF

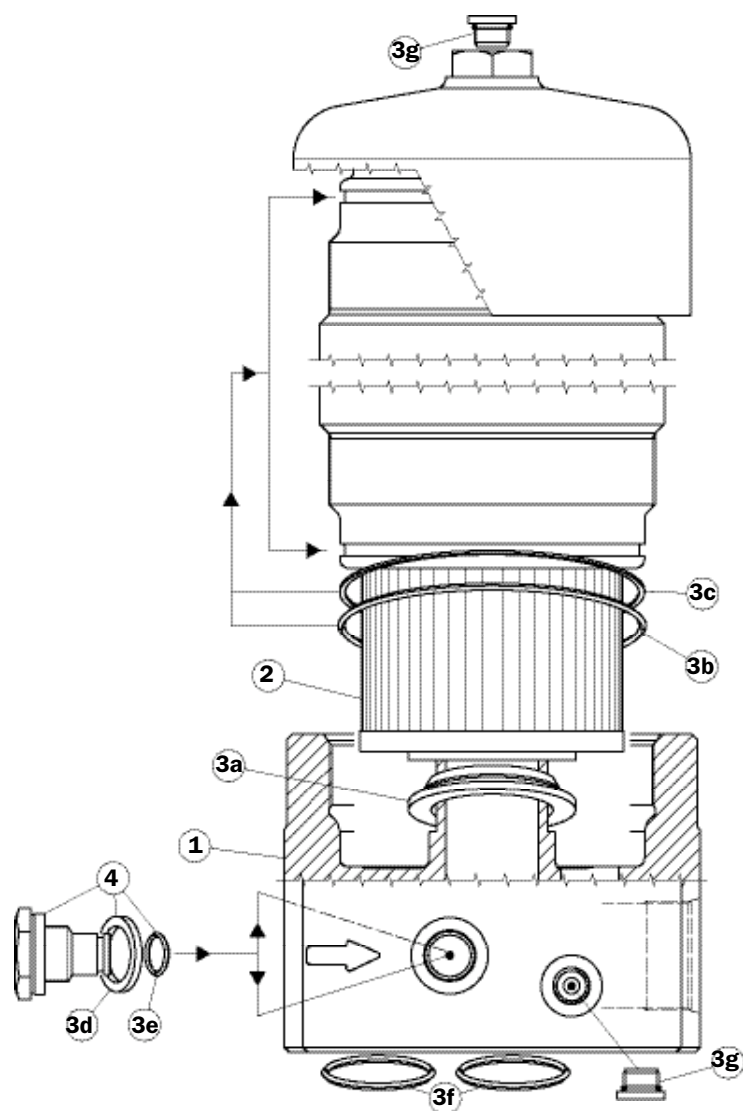

Pos.	Description	Qty.	FHF Series FILTER 320 1 - 2 - 3	
1	Complete filter	1	See order table	
2	Filter element	1	See order table	
3	Seal kits	1	NBR 02050414	FPM 02050415
3a	O-Ring for filter element	2	01026566	01026585
3b	O-Ring for housing	2	OR 3425 Ø 107.62 x 2.62	
3c	Anti-extrusion ring	2	Parbak 156 Ø 108.41 x 2.18	
3d	Gasket	2	01030058 (HNBR)	01030046 (FPM)
3e	O-Ring	2	OR 2050 Ø 12.42 x 1.78	
3f	O-Ring for head	2	OR 3150 Ø 37.77 x 2.62	
3g	Vent and drain plug	3	SAE 5	
4	Indicator plug	2	T2H	T2V
-	Indicator	1	See order table	

Ordering information FHF

Filter assembly FHF 320

Example: FHF

1	2	3	4	5	6	7	8
<input type="text"/>	<input type="text"/>	<input type="text"/>	<input type="text"/>	<input type="text"/>	<input type="text"/>	<input type="text"/>	<input type="text"/>
320	1	S	A	G1	A03	N	P01

Filter element HF 320

Example: HF

1	2	6	4	7	8
<input type="text"/>	<input type="text"/>	<input type="text"/>	<input type="text"/>	<input type="text"/>	<input type="text"/>
320	1	A03	A	N	P01

1 - Size

2 - Filter length

3 - Valves

Without bypass

With bypass

4 - Seals

NBR

FPM

5 - Connections

Type **320**

G 1-1/2"

1-1/2" NPT

SAE 24

SAE 20

Manifold

1-1/2" SAE 6000 PSI/M

1-1/2" SAE 6000 PSI/UNC

6 - Filter elements

Inorganic microfibre 3 μ

Inorganic microfibre 6 μ

Inorganic microfibre 10 μ

Inorganic microfibre 16 μ

Inorganic microfibre 25 μ

Stainless steel mesh 25 μ (style N only)

$\beta_x(c) \geq 1000$
see page 10

7 - Filter elements collapse pressure

20 bar

210 bar

8 - Options

MP Filtri standard

Customer request

DIFFERENTIAL INDICATORS (see page 15)

MP Filtri - The filter functions as described in this bulletin are valid exclusively for original MP Filtri filter elements and replacement parts. All rights reserved

The data in this publication is marketing information. MP Filtri reserves the right to make changes to the product described herein at any time it deems fit in relation to technical or commercial requirements. The colors of the products shown on the cover are for illustration purposes only. Copyright. All rights reserved.