

FHM

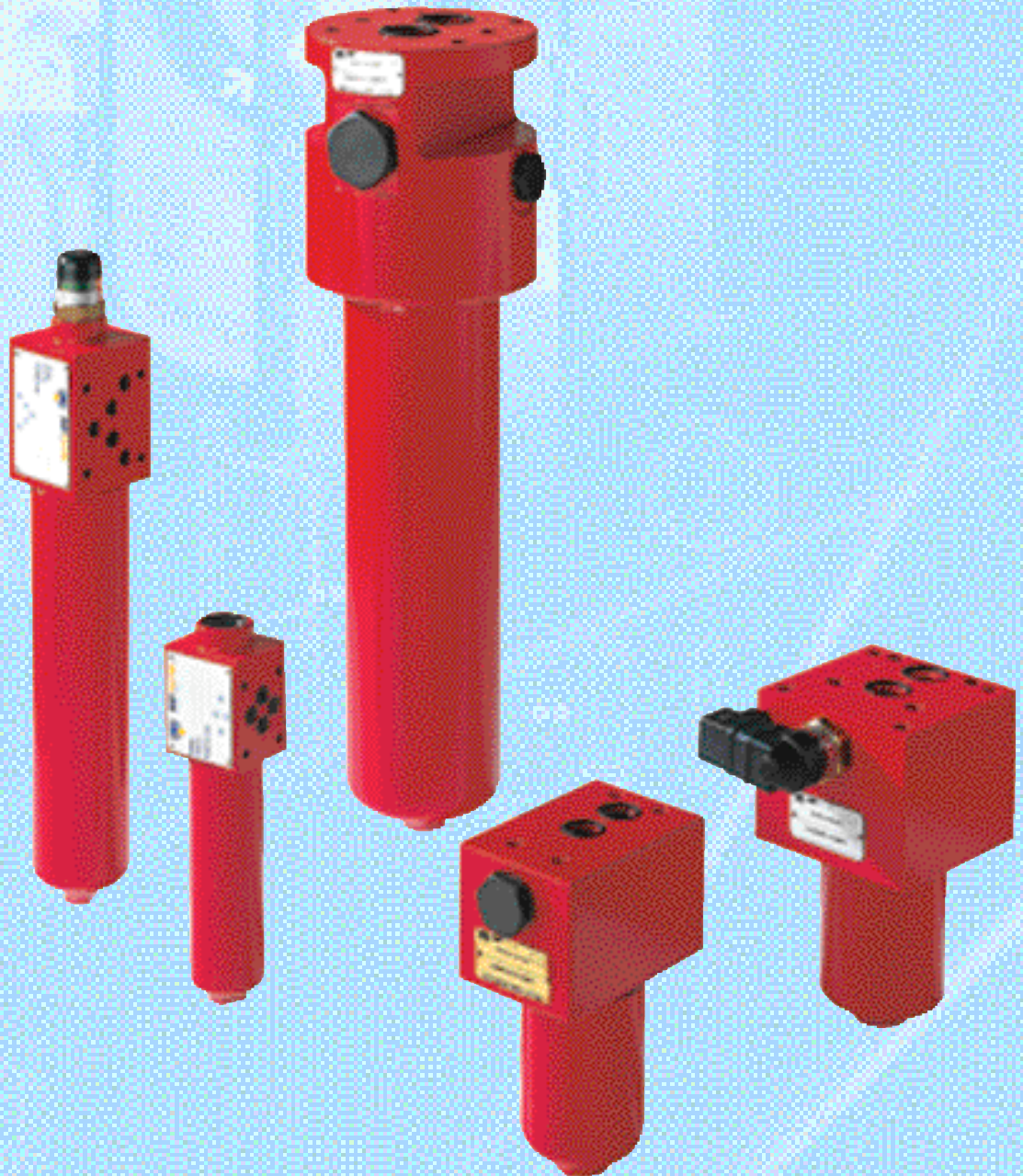

SERIES FHM

*Working pressure
320 bar*

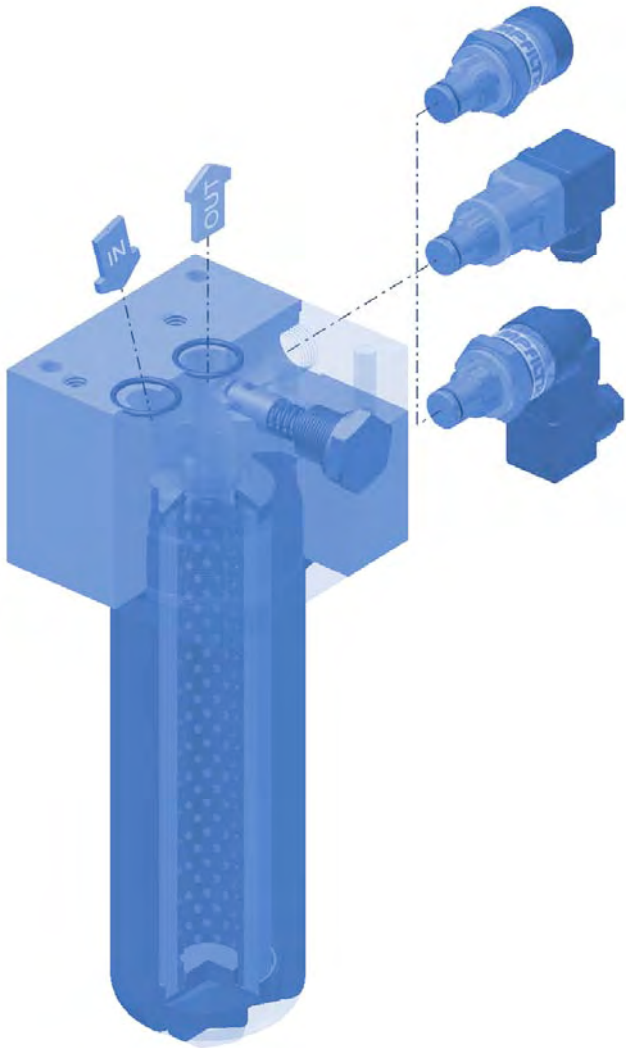
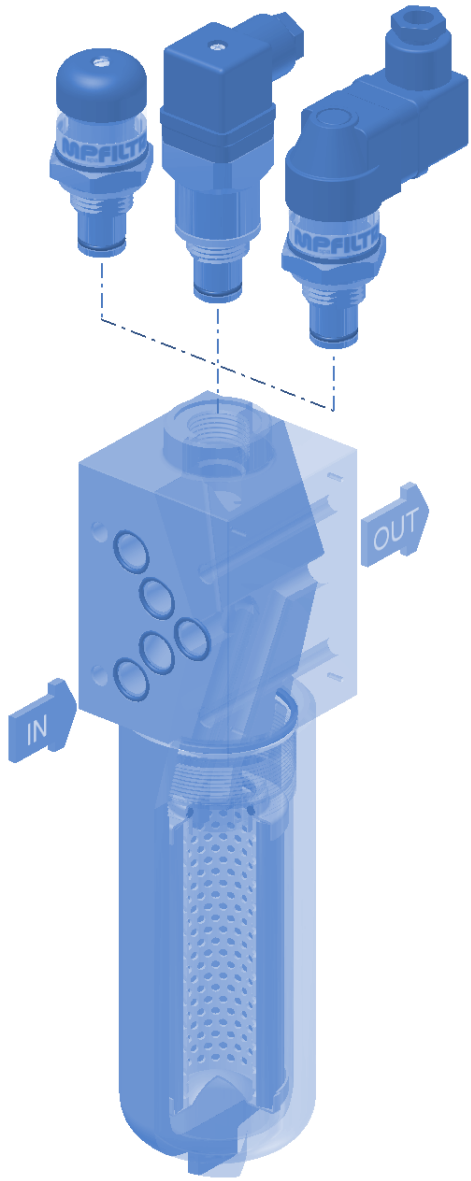

Style S

Style B

Style T

Style D

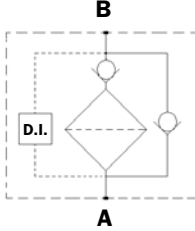
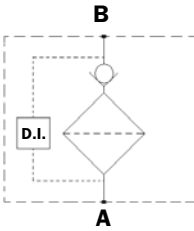
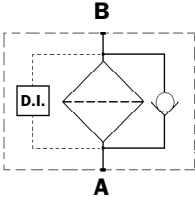
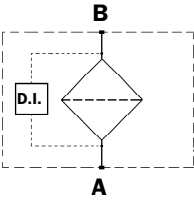

Technical data

Filter body (Materials)

- Head: Steel for size 006-010-065-135-320
- Housing: Steel (chemical heat treatment)
- Bypass valve: Brass
- Reverse Flow: Steel
- Check valve: Steel

Pressure

- Maximum operating pressure: 320 bar (32 MPa)
- Test pressure: 420 bar (42 MPa)
- Burst pressure: 840 bar (84 MPa)
- Pulsed pressure fatigue test 1,000,000 cycles with pressure from 0 to 320 bar (32 MPa)

Temperature

- From -25°C to +110°C

Bypass valve

- Opening pressure 6 bar \pm 10%
- Other opening pressures on request.

Elements type Δp

- Elements in microfibre series N : 20 bar
- Elements in microfibre series H : 210 bar
- Elements in stainless steel mesh series N : 20 bar
- Oil flow from exterior to interior.

Seals

- Standard Nitrile (NBR) series A
- Optional FPM series V

Weights without filter elements (kg.)

Length	1	2	3	4	5
• FHM 006	2.5	-	-	-	-
• FHM 010	-	5.5	6	-	-
• FHM 050	5.5	5.8	6.3	8.9	11.5
• FHM 065	5.65	6.2	7.4	-	-
• FHM 135	13	15	16.5	-	-
• FHM 320	21	23.5	26	28.8	-
• FHM 500	35	40	46	58	67

Filter internal volumes (dm³)

Length	1	2	3	4	5
• FHM 006	0.02	-	-	-	-
• FHM 010	-	0.26	0.35	-	-
• FHM 050	0.32	0.38	0.58	0.65	0.98
• FHM 065	0.34	0.40	0.62	-	-
• FHM 135	0.61	0.95	1.17	-	-
• FHM 320	1.66	1.95	2.72	3.55	-
• FHM 500	2.64	3.43	4.10	5.05	-

Connections

Manifold Inlet/Outlet

Compatibility

- Bodies compatible with:
Mineral oils to ISO 2943 - aqueous emulsions
Synthetic fluids, water/glycol.
- Filter elements compatible with:
Mineral oils to ISO 2943 - aqueous emulsions
Synthetic fluids, water/glycol.
- Nitrile (NBR) seals series A, compatible with:
Mineral oils to ISO 2943 - aqueous emulsions
synthetic fluids, water/glycol.
- V series FPM seals, compatible with:
Synthetic fluids type HS-HFDR-HFDS-HFDU.

Filter Element Area

Filter element in stainless steel mesh

Type	Length				
	1	2	3	4	5
HP020	278				
HP050	450	700	1000	1300	2100
HP065	374	530	1064	-	
HP135	950	2020	2700	-	
HP320	1650	3645	5970	8280	
HP500	3030	4900	6500	9800	13000

Values expressed in cm²

Pressure drops Δp Housing

The curves are plotted using mineral oil with density of 0.86 kg/dm³ to ISO 3968.

Δp varies proportional with density.

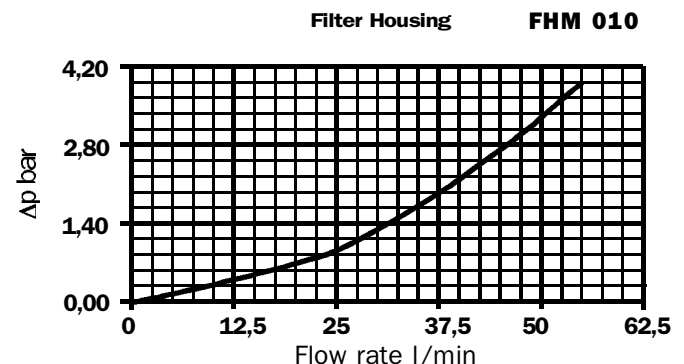
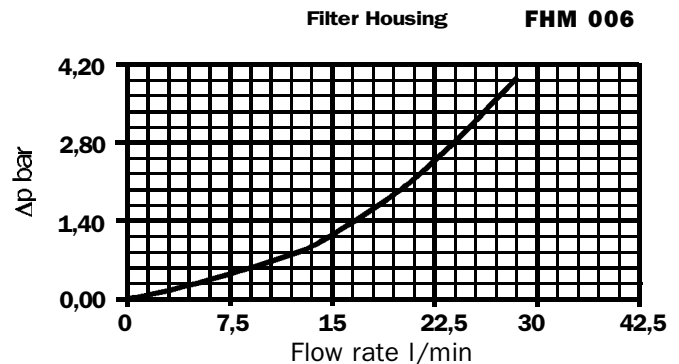

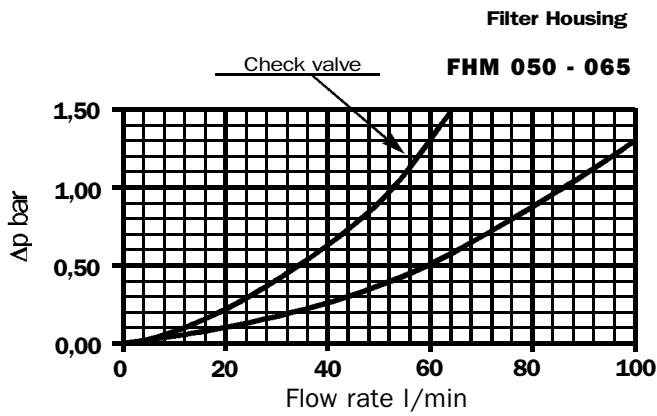

Valves

By-pass valve pressure drop

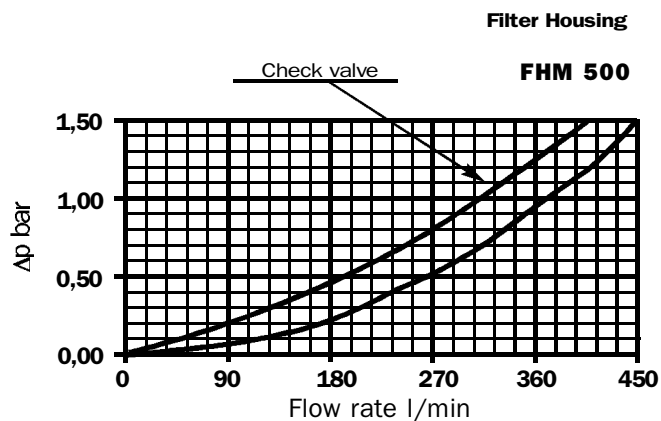
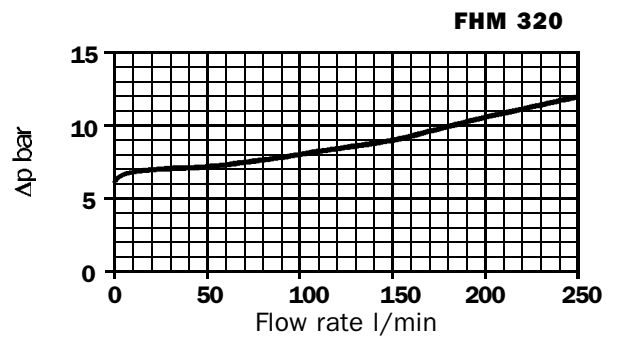
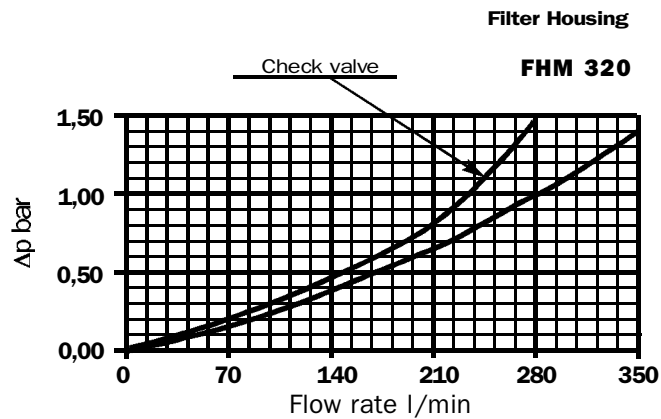
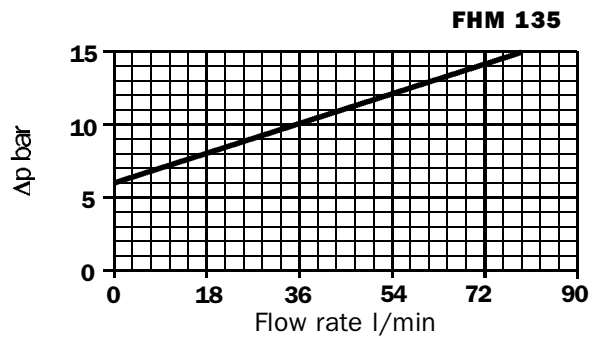
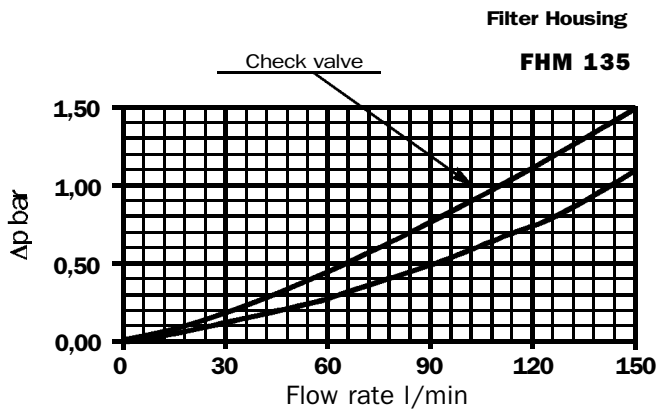
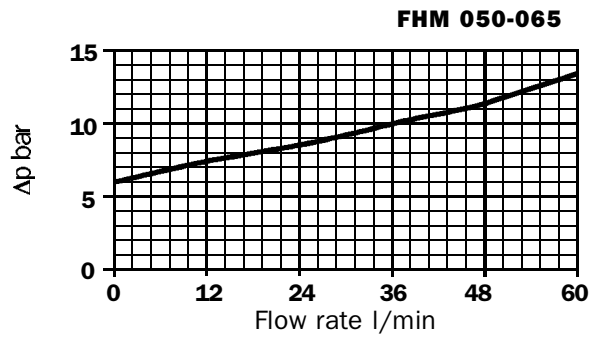

FHM 006

View with housing side "A"

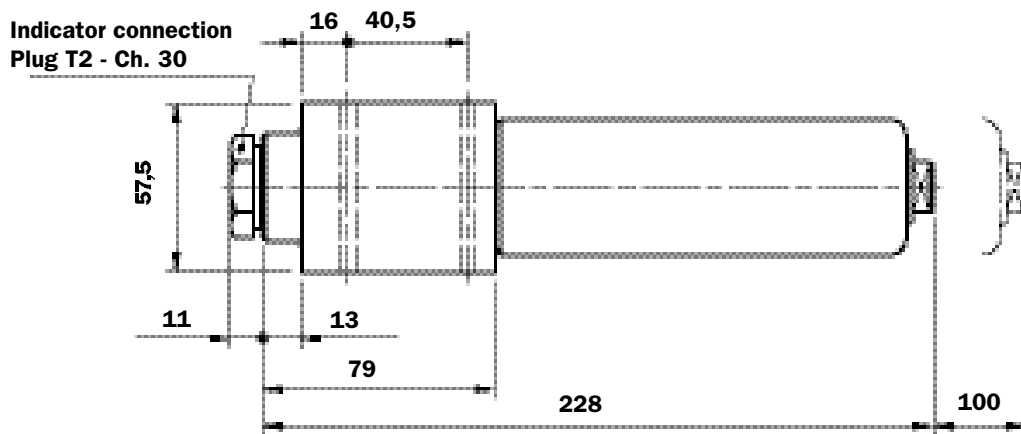
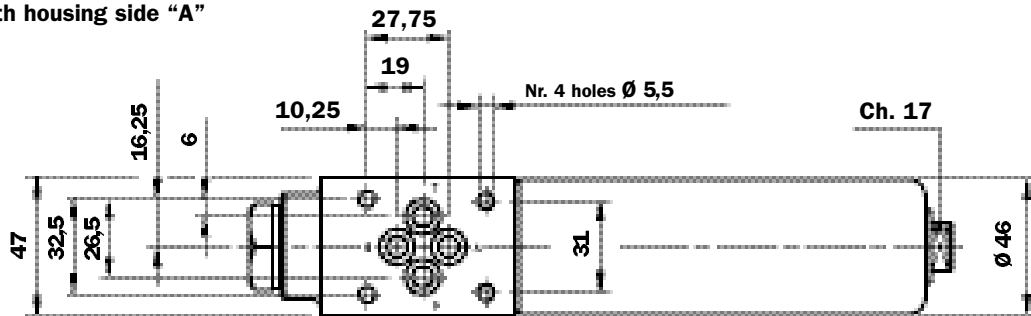

Housing side "A" = G1

Housing side "B" = G2

Recommended maximum flow rate

- Pressure drop of complete filter equal to Δp 1.5 bar.
- Oil kinematic viscosity 30 mm²/s (cSt).
- Density 0.86 kg/dm³.

Filter element type	Flow rate l/min Series H	Housing Length
A03	9	1
A06	10	
A10	13	
A16	13	
A25	15	
M25	17	

FHM 010

View with housing side "B"

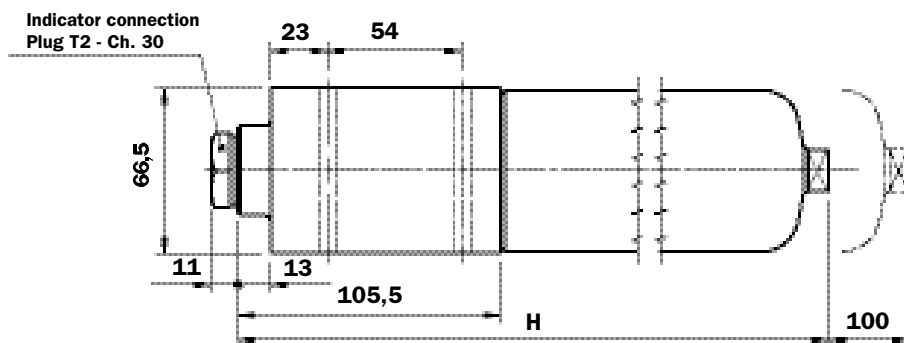
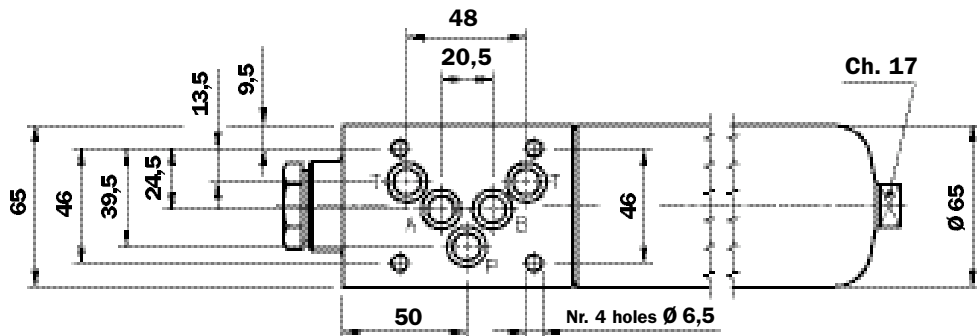

Housing side "A" = G1
Housing side "B" = G2

Recommended maximum flow rate

- Pressure drop of complete filter equal to Δp 1.5 bar.
- Oil kinematic viscosity 30 mm²/s (cSt).
- Density 0.86 kg/dm³.

Filter Length	H mm
2	282
3	383

Filter element type	Flow rate l/min Series H	Housing Length
A03	19	2
A06	21	
A10	25	
A16	26	
A25	29	
M25	-	
A03	24	3
A06	26	
A10	29	
A16	29	
A25	31	
M25	-	

FHM 050

FHM 065

FHM 050

Recommended maximum flow rate

- Pressure drop of complete filter equal to Δp 1.5 bar.
- Oil kinematic viscosity 30 mm²/s (cSt).
- Density 0.86 kg/dm³.

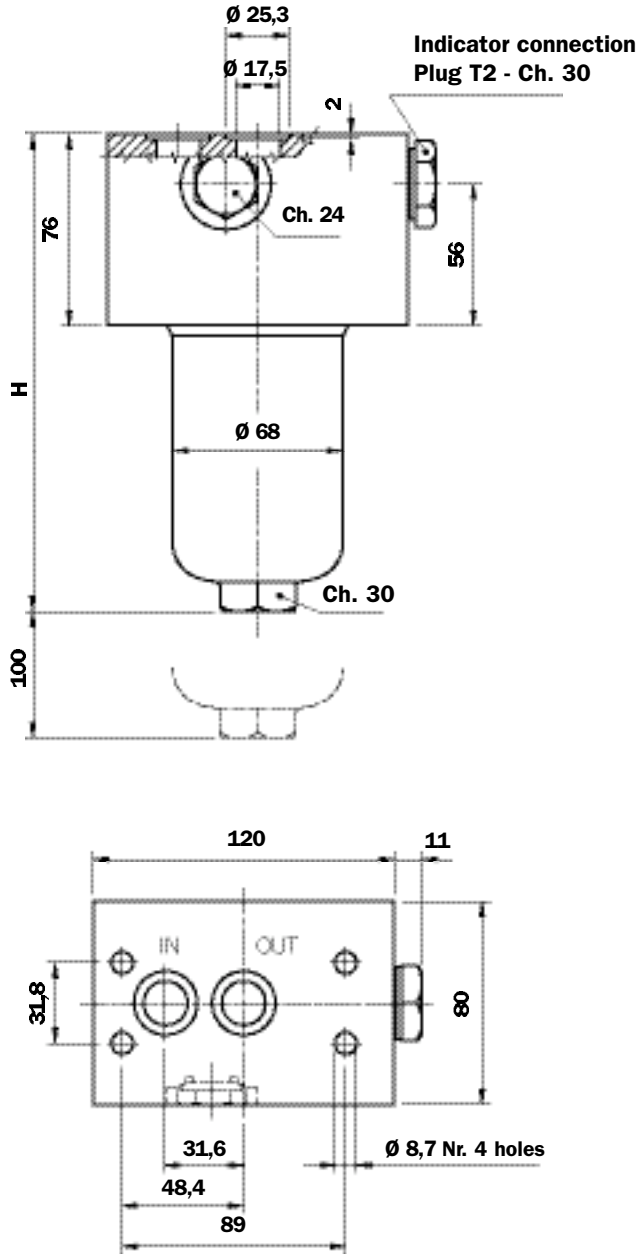

Filter element type	Flow rate l/min Series N	Flow rate l/min Series H	Filter Length
A03	38	28	1
A06	38	36	
A10	65	50	
A16	67	52	
A25	80	62	
M25	102	-	
A03	46	41	2
A06	50	45	
A10	68	62	
A16	75	70	
A25	87	85	
M25	105	-	
A03	56	50	3
A06	60	55	
A10	76	72	
A16	80	78	
A25	92	91	
M25	105	-	
A03	68	62	4
A06	70	65	
A10	85	80	
A16	86	82	
A25	95	92	
M25	105	-	
A03	82	73	5
A06	83	75	
A10	94	84	
A16	95	89	
A25	100	92	
M25	110	-	

Filter Length	H mm
1	154
2	191
3	233
4	281
5	403

FHM 065

Recommended maximum flow rate

- Pressure drop of complete filter equal to Δp 1.5 bar.
- Oil kinematic viscosity 30 mm²/s (cSt).
- Density 0.86 kg/dm³.

Filter element type	Flow rate l/min Series N	Flow rate l/min Series H	Filter Length
A03	23	22	1
A06	30	23	
A10	48	43	
A16	53	50	
A25	71	67	
M25	102	-	
A03	30	30	2
A06	45	34	
A10	59	55	
A16	64	62	
A25	80	75	
M25	105	-	
A03	51	51	3
A06	59	57	
A10	78	76	
A16	82	80	
A25	92	91	
M25	107	-	

Filter Length	H mm
1	162
2	193
3	295

FHM 135

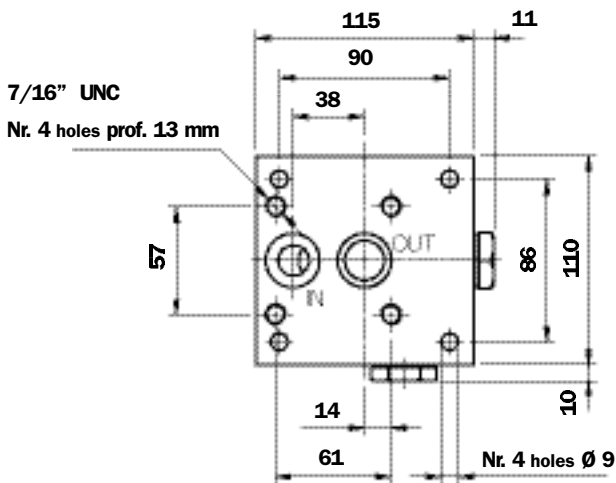
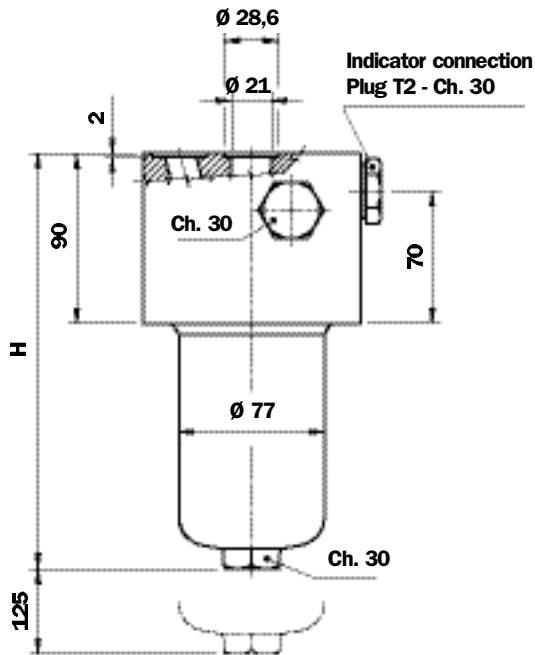

Recommended maximum flow rate

- Pressure drop of complete filter equal to Δp 1.5 bar.
- Oil kinematic viscosity 30 mm²/s (cSt).
- Density 0.86 kg/dm³.

Filter element type	Flow rate l/min Series N	Flow rate l/min Series H	Filter Length
A03	60	46	1
A06	65	51	
A10	99	84	
A16	104	86	
A25	130	122	
M25	150	-	
A03	90	79	2
A06	97	92	
A10	118	110	
A16	120	112	
A25	155	135	
M25	165	-	
A03	118	102	3
A06	120	112	
A10	143	130	
A16	145	137	
A25	160	146	
M25	165	-	

Filter Length	H mm
1	202
2	315
3	390

FHM 320

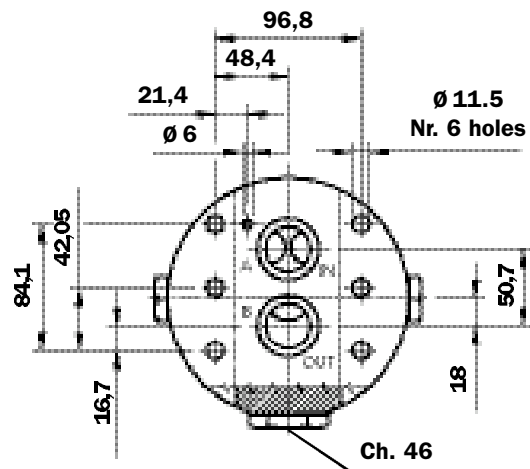
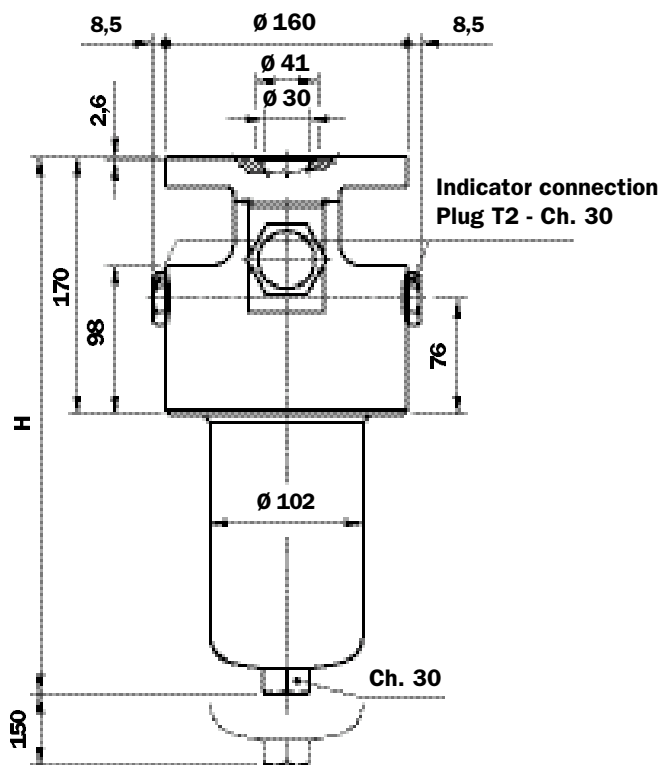

Only for FHM 320 length 4

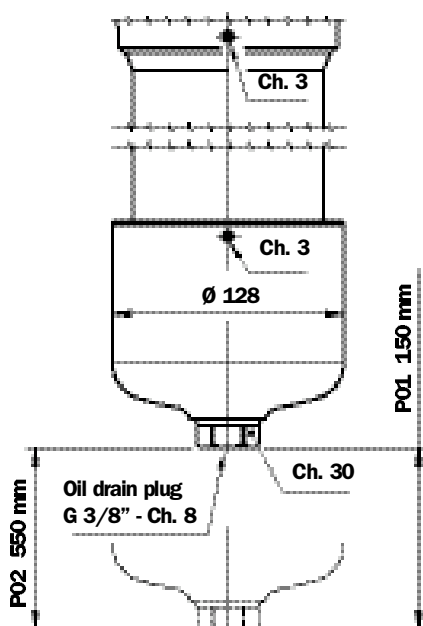

Recommended maximum flow rate

- Pressure drop of complete filter equal to Δp 1.5 bar.
- Oil kinematic viscosity 30 mm²/s (cSt).
- Density 0.86 kg/dm³.

Filter element type	Flow rate l/min Series N	Flow rate l/min Series H	Filter Length
A03	112	97	1
A06	121	104	
A10	187	156	
A16	217	162	
A25	252	228	
M25	310	-	2
A03	200	162	
A06	215	181	
A10	282	238	
A16	292	240	
A25	320	282	3
M25	330	-	
A03	246	206	
A06	268	233	
A10	311	275	
A16	320	280	4
A25	325	305	
M25	332	-	
A03	266	234	
A06	280	246	
A10	315	280	4
A16	325	285	
A25	336	313	
M25	345	-	

Filter Length **H mm**

1	293
2	416
3	548
4	702

Style P01 standard maintenance from head.
Style P02 maintenance option from housing base.

FHM 500

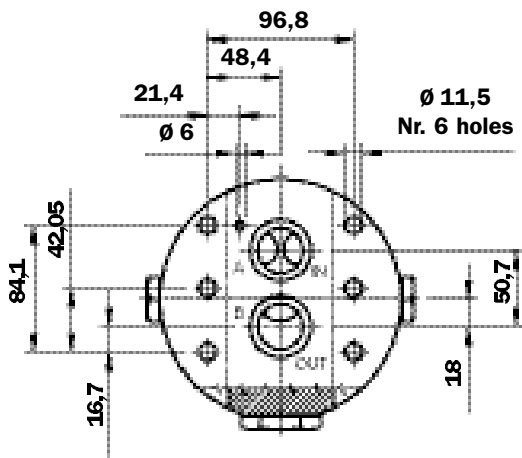
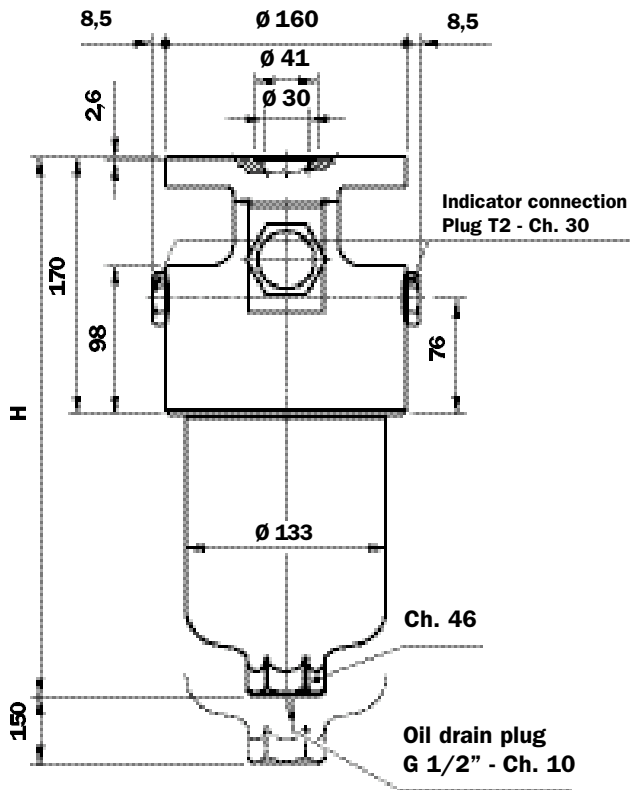

Only for FHM 500 length 4/5

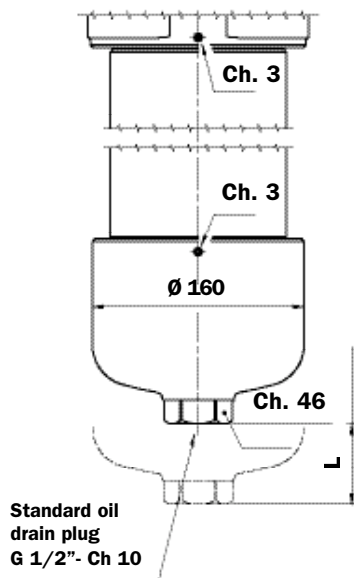

Recommended maximum flow rate

- Pressure drop of complete filter equal to Δp 1.5 bar.
- Oil kinematic viscosity 30 mm²/s (cSt).
- Density 0.86 kg/dm³.

Filter element type	Flow rate l/min Series N	Flow rate l/min Series H	Filter Length
A03	225	140	1
A06	250	155	
A10	272	235	
A16	272	235	
A25	300	295	
M25	350	-	2
A03	250	210	
A06	265	230	
A10	300	285	
A16	310	285	
A25	325	330	
M25	400	-	3
A03	285	250	
A06	290	265	
A10	315	315	
A16	320	330	
A25	330	360	
M25	400	-	4
A03	350	287	
A06	370	315	
A10	400	365	
A16	400	370	
A25	410	390	
M25	430	-	5
A03	370	348	
A06	380	350	
A10	400	385	
A16	410	395	
A25	420	410	
M25	430	-	

Filter Length **H mm**

1	358
2	448
3	524
4	680
5	846

Style P01	
L mm	Filter Length
150	4/5

Style P02	
L mm	Filter Length
480	4
650	5

Style P01 standard maintenance from head.
Style P02 maintenance option from housing base.
See tables alongside.

Spare parts FHM 006 - 010

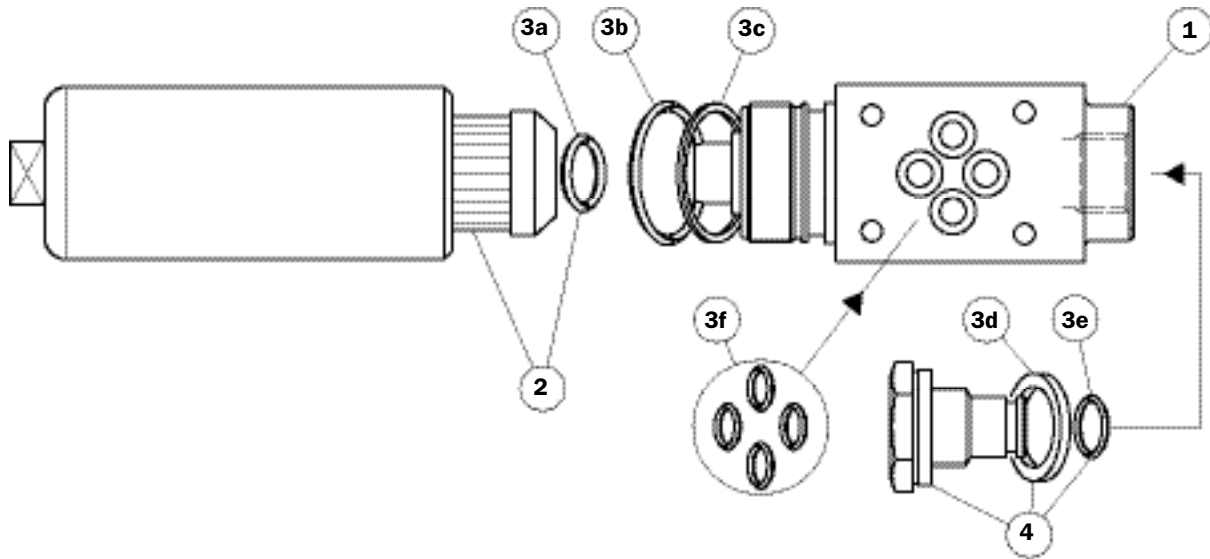

Pos.	Description	Qty.	Series FHM 006 - 010 FILTER			
			006 1		010 2 - 3	
1	Complete filter	1	See order table			
2	Filter element	1	See order table			
3	Seal kits	1	NBR 02050324	FPM 02050325	NBR 02050320	FPM 02050321
3a	O-Ring for filter element	1	OR 121 Ø 15.88 x 2.62		OR 4100 Ø 24.99 x 3.53	
3b	O-Ring for housing	1	OR 3125 Ø 31.42 x 2.62		OR 3187 Ø 47.29 x 2.62	
3c	Anti-extrusion ring	1	Parbak 124 Ø 32.21 x 2.18		Parbak 134 Ø 48.08 x 2.18	
3d	Gasket	1	01030058 (HNBR)		01030046 (FPM)	
3e	O-Ring	1	OR 2050 - Ø 12.42 x 1.78			
3f	O-Ring	4	4 pz.	OR 108 Ø 8.73 x 1.78	5 pz.	OR 2050 Ø 12.42 x 1.78
4	Indicator plug	1	T2H		T2V	
-	Indicator	1	See order table			

Spare parts FHM

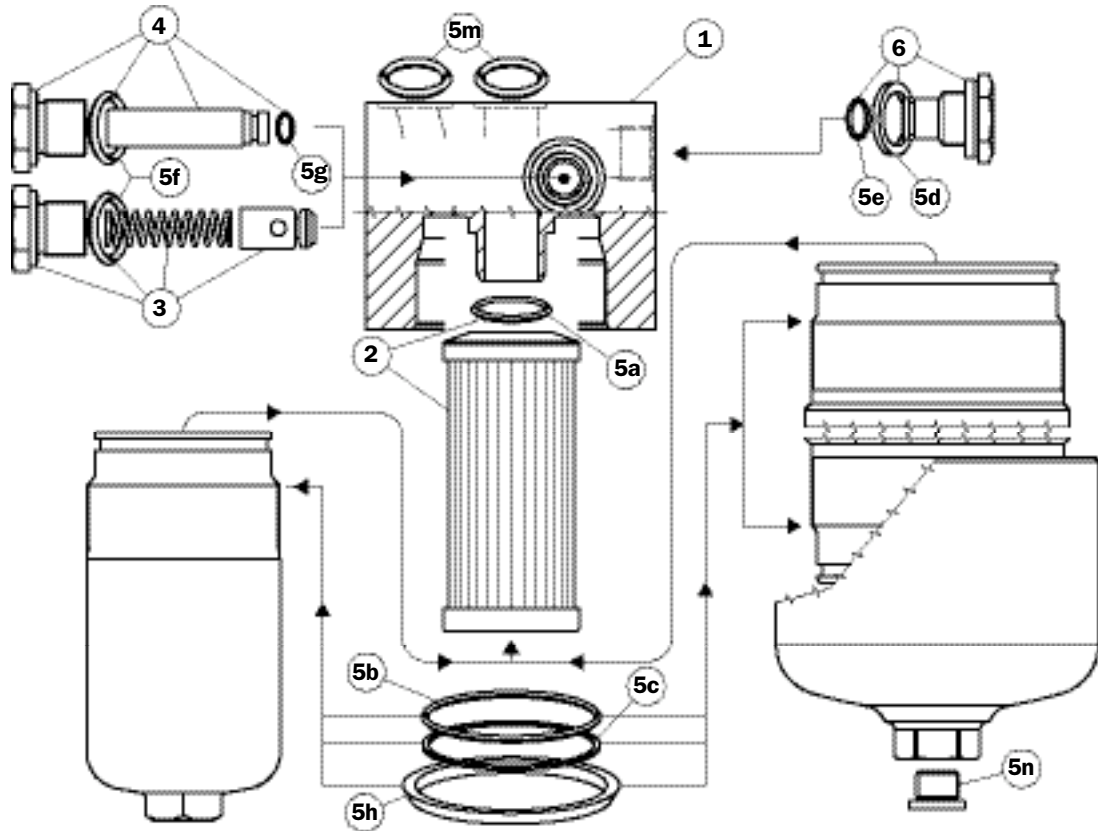

Pos.	Description	Qty.	Series FHM FILTER									
			050 1 - 2 - 3 - 4 - 5		065 1 - 2 - 3		135 1 - 2 - 3		320 1 - 2 - 3 - 4		500 1 - 2 - 3 - 4 - 5	
1	Complete filter	1	See order table									
2	Filter element	1	See order table									
3	Bypass assembly	1	02001400 (NBR) 02001401 (FPM)		02001404 (NBR) 02001405 (FPM)		02001408 (NBR) 02001411 (FPM)					
4	Non bypass assembly	1	02001402 (NBR) 02001403 (FPM)		02001406 (NBR) 02001407 (FPM)		02001410 (NBR) 02001411 (FPM)					
5	Seal kits	1	NBR 02050410	FPM 02050411	NBR 02050268	FPM 02050279	NBR 02050271	FPM 02050282	NBR 02050275	FPM 02050286	NBR 02050332	FPM 02050333
5a	Filter element O-Ring	1	OR 3093 Ø 23.47 x 2.62		OR 4100 Ø 24.99 x 3.53		OR 3106 Ø 26.65 x 2.62		OR 144 Ø 39.69 x 3.53		OR 153 Ø 49.21 x 3.53	
5b	O-Ring for housing	1	OR 3225 Ø 56.82 x 2.62		OR 159 Ø 55.56 x 3.53		OR 3256 Ø 64.77 x 2.62		2 pcs. Ø 88.57 x 2.62	OR 3350	2 pcs. Ø 117.10 x 3.53	OR 4462
5c	Anti-extrusion ring	1	Parbak 139 Ø 56.03 x 2.18		Parbak 227 Ø 54.53 x 3		Parbak 144 Ø 63.96 x 2.18		2 pcs. Ø 89.36 x 2.18	Parbak 153	2 pcs. Ø 117.63 x 3	Parbak 247
5d	Gasket	1	01030058 (HNBR)	01030046 (FPM)	01030058 (HNBR)	01030046 (FPM)	01030058 (HNBR)	01030046 (FPM)	01030058 (HNBR)	01030046 (FPM)	01030058 (HNBR)	01030046 (FPM)
5e	O-Ring	1	OR 2050 Ø 12.42 x 1.78									
5f	Bp or No Bp O-Ring	1	OR 121 (NBR 90 Sh A) Ø 15.88 x 2.62		OR 3087(NBR 90 Sh A) Ø 21.89 x 2.62		OR 3143 (NBR 90 Sh A) Ø 36.17 x 2.62					
5g	No Bp O-Ring	1	OR 2031 Ø 7.65 x 1.78		OR 2037 Ø 9.25 x 1.78		OR 3108 Ø 26.64 x 2.62					
5h	Protective seal	1	01026521		01026509		01026510				-	
5m	O-Ring for head	2	OR 3081 Ø 20.29 x 2.62		OR 3093 Ø 23.47 x 2.62		OR 4137 Ø 34.52 x 3,53					
5n	Oil drain plug	1	-		-		G 3/8" with seal		G 1/2" with seal			
-	Indicator	1	See order table									
6	Indicator plug	1	T2H					T2V				

Ordering information FHM

Filter assembly FHM

Example: FHM

1	2	3	4	5	6	7	8a
006	1	S	A	G1	A03	H	P01

Filter element HP

Example: HP

1	2	6	4	7	8 b
020	1	A03	A	H	P01

1 - Size

Filter	Filter element
006	020
010	065
050	050
065	065
135	135
320	320
500	500

2 - Filter length

	006	010	050	065	135	320	500
1	X		X	X	X	X	X
2		X	X	X	X	X	X
3		X	X	X	X	X	X
4			X			X	X
5			X				X

3 - Valves

S	Without bypass
B	With bypass
T	without bypass + check valve*
D	with bypass + check valve*

N.B Sizes 006-010 are available only in **S** version without bypass.

*Reduced cross-section oilways

4 - Seals

A	NBR
V	FPM

5 - Connections

G1	Housing side A (only for 006 and 010)
G2	Housing side B (only for 006 and 010)
F1	Only for 050-065-135-320-500

6 - Filter elements

A03	Inorganic microfibre 3 μ	} 6x (c) \geq 1000 See page 10
A06	Inorganic microfibre 6 μ	
A10	Inorganic microfibre 10 μ	
A16	Inorganic microfibre 16 μ	
A25	Inorganic microfibre 25 μ	
M25	Stainless steel mesh 25 μ (style N only)	

7 - Filter elements collapse pressure

N	20 bar
S	210 bar (only for size 500)
H	210 bar

8 - Options

a) Filter

P01	MP Filtri standard
P02	Maintenance from base of housing (only FHM 320 4 - FHM 500 4 - 5)
Pxx	Customer request

b) Filter element

P01	MP Filtri standard
Pxx	Customer request

DIFFERENTIAL INDICATORS (see page 15)

MP Filtri - The filter functions as described in this bulletin are valid exclusively for original MP Filtri filter elements and replacement parts. All rights reserved

The data in this publication is marketing information. MP Filtri reserves the right to make changes to the product described herein at any time it deems fit in relation to technical or commercial requirements. The colors of the products shown on the cover are for illustration purposes only. Copyright. All rights reserved.