

# LMP 210



# LMP

## SERIES 210

*Working pressure  
60 bar*

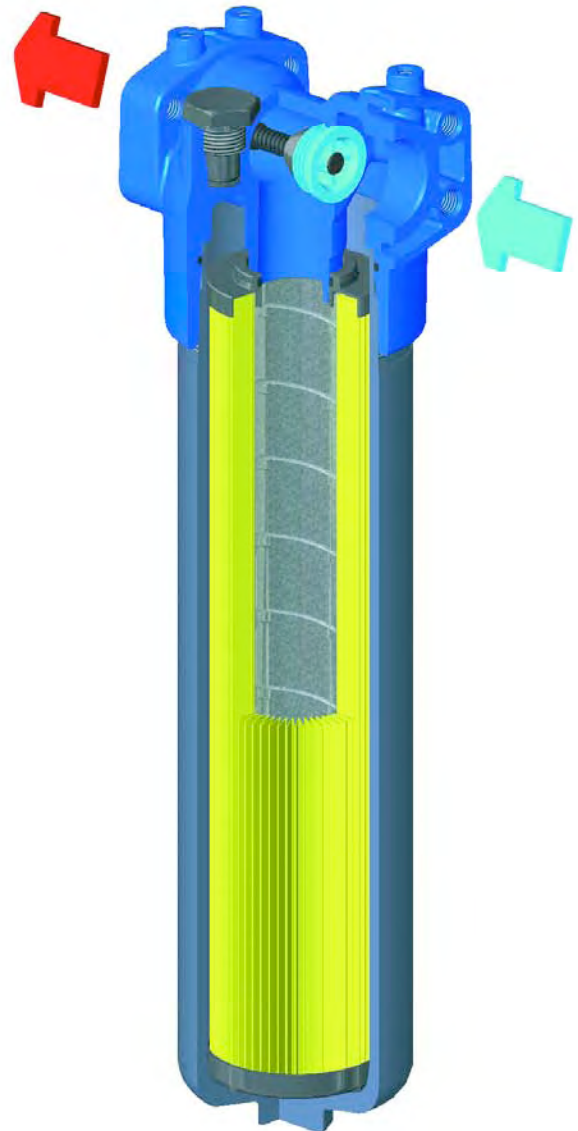

Style **S**

Style **B**

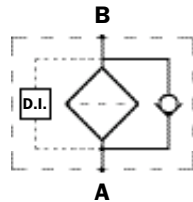
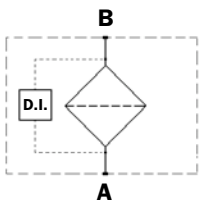

# Technical data

## Filter housing (Materials)

- Head: Anodised Aluminium
- Housing: Anodised Aluminium
- Bypass valve: Nylon

## Pressure

- Working pressure: 60 bar (6 MPa)
- Test pressure: 90 bar (9 MPa)
- Burst pressure: 180 bar (18 MPa)
- Pulsed pressure fatigue test: 1.000.000 cycles with pressure from 0 to 60 bar (6 MPa)

## Temperature

- From -25°C to +110°C

## Bypass valve

- Opening pressure 3.5 bar  $\pm$ 10%
- Other opening pressures on request.

## $\Delta p$ Elements type

- Series N and W elements: 20 bar
- Oil flow from exterior to interior.

## Seals

- Standard NBR series A
- Optional FPM series V

## Weights (kg)

### Length

- LMP210 -1 3.5
- LMP210 -2 4.4
- LMP210 -3 5.4

## Volumes (dm<sup>3</sup>)

### Length

- LMP210 -1 1.5
- LMP210 -2 2
- LMP210 -3 2.7

## Connections

In-line Inlet/Outlet LMP 210

## Compatibility

- Housings compatible with:  
Mineral oils to ISO 2943 - aqueous emulsions  
synthetic fluids, water and glycol.
- The filter elements are compatible with:  
Mineral oils to ISO 2943, Synthetic fluids  
Aqueous emulsions, water and glycol  
(series W required).
- NBR seals series A, compatible with:  
Mineral oils to ISO 2943 - aqueous emulsions  
synthetic fluids, water and glycol.
- V series FPM seals, compatible with:  
Synthetic fluids type HS-HFDR-HFDS-HFDU  
To ISO 2943

## Filter Element Area

Filter element in stainless steel mesh  
Length

Type	1	2	3
CU 210	3100	4950	7520
Values expressed in cm <sup>2</sup>			

## Filter housing $\Delta p$ pressure drop

The curves are plotted utilising mineral oil with density of 0.86 kg/dm<sup>3</sup> to ISO 3968.

$\Delta p$  varies proportionally with density.

LMP 210 -  $\Delta p$  Housing

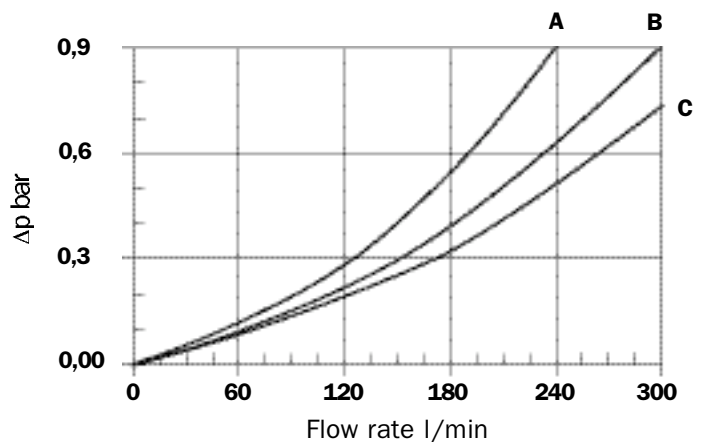

## Valves

### Bypass valve pressure drop

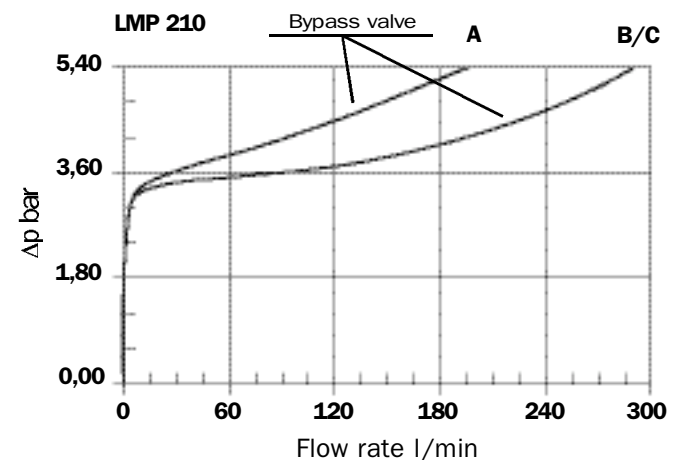

Filter housing and valves  $\Delta p$  pressure drop connection

## Connection (dimensions page 23)

Type	Connection (dimensions page 23)
A	G1 - G4 - G7 - F1 - F4
B	G2 - G5 - G8 - F2 - F5
C	G3 - G6 - G9 - F3 - F6

## Recommended maximum flow rate

- Pressure drop of filter assembly equal to  $\Delta p$  0,6 bar.
- Oil kinematic viscosity 30 mm<sup>2</sup>/s (sCt).
- Density 0,86 kg/dm<sup>3</sup>.
- Connections of filter under test G 3".

Filter element type	Flow rate l/min Series N Filter length		
	1	2	3
A03	98	140	190
A06	120	162	200
A10	175	205	235
A16	185	225	245
A25	208	235	250
M25	265	270	270
P10	245	250	260
P25	250	255	268

## LMP 210

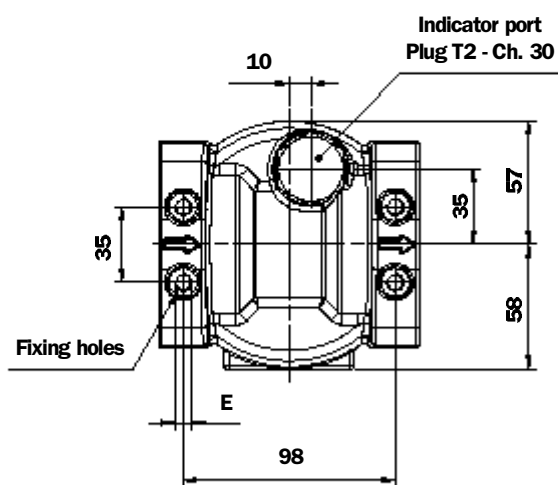
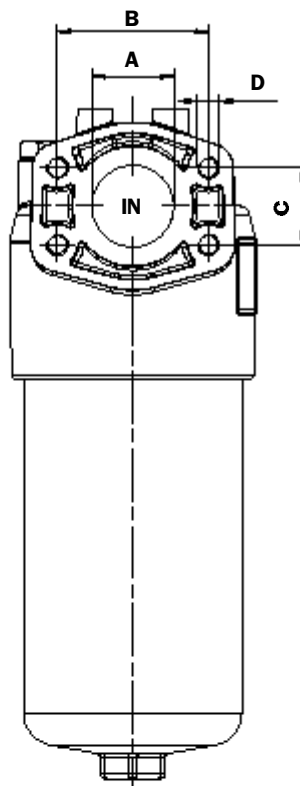
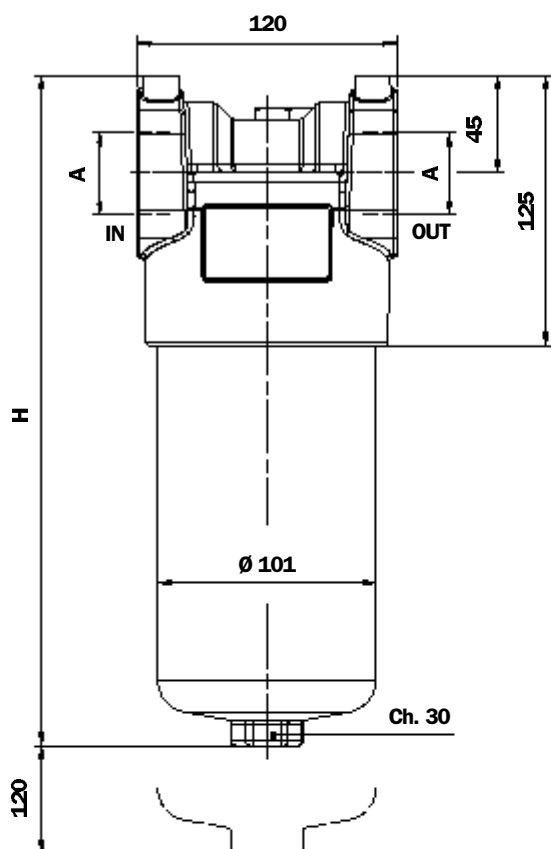

### Threaded Connections

Type	Connection "A"	E Depth 12 mm
G1	G1	M8
G2	G 1 1/4"	M8
G3	G 1 1/2"	M8
G4	1" NPT	5/16" UNC
G5	1 1/4" NPT	5/16" UNC
G6	1 1/2" NPT	5/16" UNC
G7	SAE 16 1 5/16" 12 UN	5/16" UNC
G8	SAE 20 1 5/8" 12 UN	5/16" UNC
G9	SAE 24 1 7/8" 12 UN	5/16" UNC

Filter Length H mm

1	360
2	492
3	630

### Flanged Connections

Type	Connection "A"	"B"	"C"	"D"	E Depth 12 mm
F1	1" SAE - 3000 psi/M	52,37	26,19	M10	M8
F2	1 1/4" SAE - 3000 psi/M	58,72	30,18	M10	M8
F3	1 1/2" SAE - 3000 psi/M	69,85	35,71	M12	M8
F4	1" SAE - 3000 psi/UNC	52,37	26,19	3/8" UNC	5/16" UNC
F5	1 1/4" SAE - 3000 psi/UNC	58,72	30,18	7/16" UNC	5/16" UNC
F6	1 1/2" SAE - 3000 psi/UNC	69,85	35,71	1/2" UNC	5/16" UNC

# LMP 210 spare parts

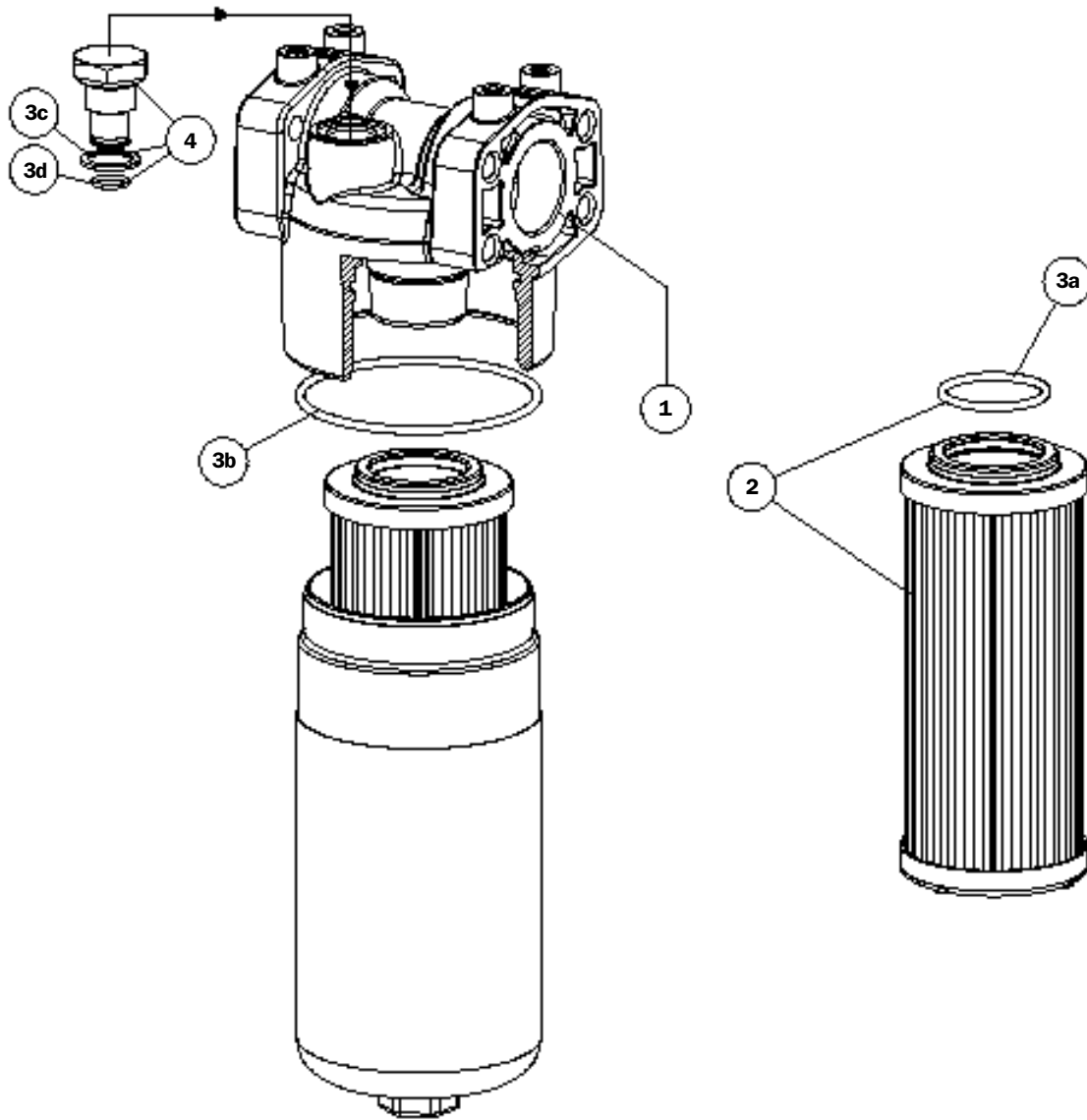

Pos.	Description	Qty	FILTER Series LMD 401	
1	Filter assembly	1	See order table	
2	Filter element	1	See order table	
3	Seals kit	1	NBR 02050435	FPM 02050436
3a	O-Ring filter element	1	O-R 144 Ø 39,69 x 3,53	
3b	O-Ring housing	1	O-R 4375 Ø 94,84 x 3,53	
3c	Seal	1	01030058	01030046
3d	O-Ring	2	O-R 2050 Ø 12,42 x 1,78	
4	Indicator plug	1	T2H	T2V
-	Indicators	1	See order table	

# LMP 210 ordering information

## Filter assembly LMP210

Example: LMP210

<b>1</b>	<b>2</b>	<b>3</b>	<b>4</b>	<b>5</b>	<b>6</b>	<b>7</b>
<input type="checkbox"/>	<input type="checkbox"/>	<input type="checkbox"/>	<input type="checkbox"/>	<input type="checkbox"/>	<input type="checkbox"/>	<input type="checkbox"/>
<b>2</b>	<b>B</b>	<b>A</b>	<b>G3</b>	<b>A10</b>	<b>N</b>	<b>P01</b>

## Filter Element CU210

Example: CU210

<b>1</b>	<b>5</b>	<b>3</b>	<b>6</b>	<b>7</b>
<input type="checkbox"/>	<input type="checkbox"/>	<input type="checkbox"/>	<input type="checkbox"/>	<input type="checkbox"/>
<b>2</b>	<b>A10</b>	<b>A</b>	<b>N</b>	<b>P01</b>

### 1 - Sizes

<b>1</b>
<b>2</b>
<b>3</b>

### 3 - Valves

<b>S</b>	Without by-pass
<b>B</b>	With by-pass

### 4 - Seals

<b>A</b>	NBR
<b>V</b>	FPM

### 5 - Connections

#### Threaded

<b>G1</b>	G 1"
<b>G2</b>	G 1 1/4"
<b>G3</b>	G 1 1/2"
<b>G4</b>	1" NPT
<b>G5</b>	1 1/4" NPT
<b>G6</b>	1 1/2" NPT
<b>G7</b>	SAE 16 1 5/16" 12UN
<b>G8</b>	SAE 20 1 5/8" 12UN
<b>G9</b>	SAE 24 1 7/8" 12UN

#### Flanged

<b>F1</b>	1" SAE 3000 psi/M
<b>F2</b>	1 1/4" SAE 3000 psi/M
<b>F3</b>	1 1/2" SAE 3000 psi/M
<b>F4</b>	1" SAE 3000 psi/UNC
<b>F5</b>	1 1/4" SAE 3000 psi/UNC
<b>F6</b>	1 1/2" SAE 3000 psi/UNC

### 6 - Filter element

<b>A03</b>	3 µm	<b>A16</b>	16 µm	Absolute filtration Inorganic microfibre βx (c) ≥ 1000
<b>A06</b>	6 µm	<b>A25</b>	25 µm	
<b>A10</b>	10 µm			
<b>M25</b>	25 µm	<b>M90</b>	90 µm	Nominal Filtration Metal mesh
<b>M60</b>	60 µm			
<b>P10</b>	10 µm			Nominal Filtration Cellulose
<b>P25</b>	25 µm			

### 7 - Filter elements series

<b>N</b>	Δp 20 bar
<b>W</b>	Δp 20 bar Compatible with fluid FH AFH BFH C (not available for filter element Pxx)

### 8 - Options

#### a - Filter

<b>P01</b>	MP Standard filters
------------	---------------------

DIFFERENTIAL INDICATORS (see page 12)

**MP Filtri** - The filter functions as described in this bulletin are valid exclusively for original MP Filtri filter elements and replacement parts. All rights reserved

The data in this publication are purely guideline. MP Filtri reserves the right to make changes to the models described herein at any time it deems fit in relation to technical or commercial requirements. The colours of the products shown on the cover are purely guideline. Copyright. All rights reserved.