

# SERIES MSH

**SPIN-ON FILTER - LOW PRESSURE LINE**



**MPFILTRI**<sup>®</sup>  
filtri per oleodinamica



Maximum working pressure 500 psi

Flow rate to 80 GPM

# D e s c r i p t i o n

## MSH

This filter **MSH** series utilises spin-on canisters, with flow capabilities of 80 gpm and has a maximum working pressure of 500 psi, with a peak pressure rating of 700 psi.

Technically, the **MSH** filters is a new concept, as the filter canister is seamless. Our unique sealing system ensures that the product will withstand medium pressure up to 700 psi.

The **MSH** filters feature a bypass valve and utilise a pressure differential indicator. A patented (no.22083A/86) head/bowl sealing system ensures leak free filters every time.

The **MSH** series is particularly suitable for use on supercharging or auxiliary, low-pressure lines. Ideally suited for use in a servo-assisted hydrostatic transmission where the servo line requires high-performance filtration at medium working pressures.

### INDICATORS

#### New

absolute filter elements  
independently tested  
in the following Institutes:

Institute of Filtration  
(France)



Royal Institute of Technology

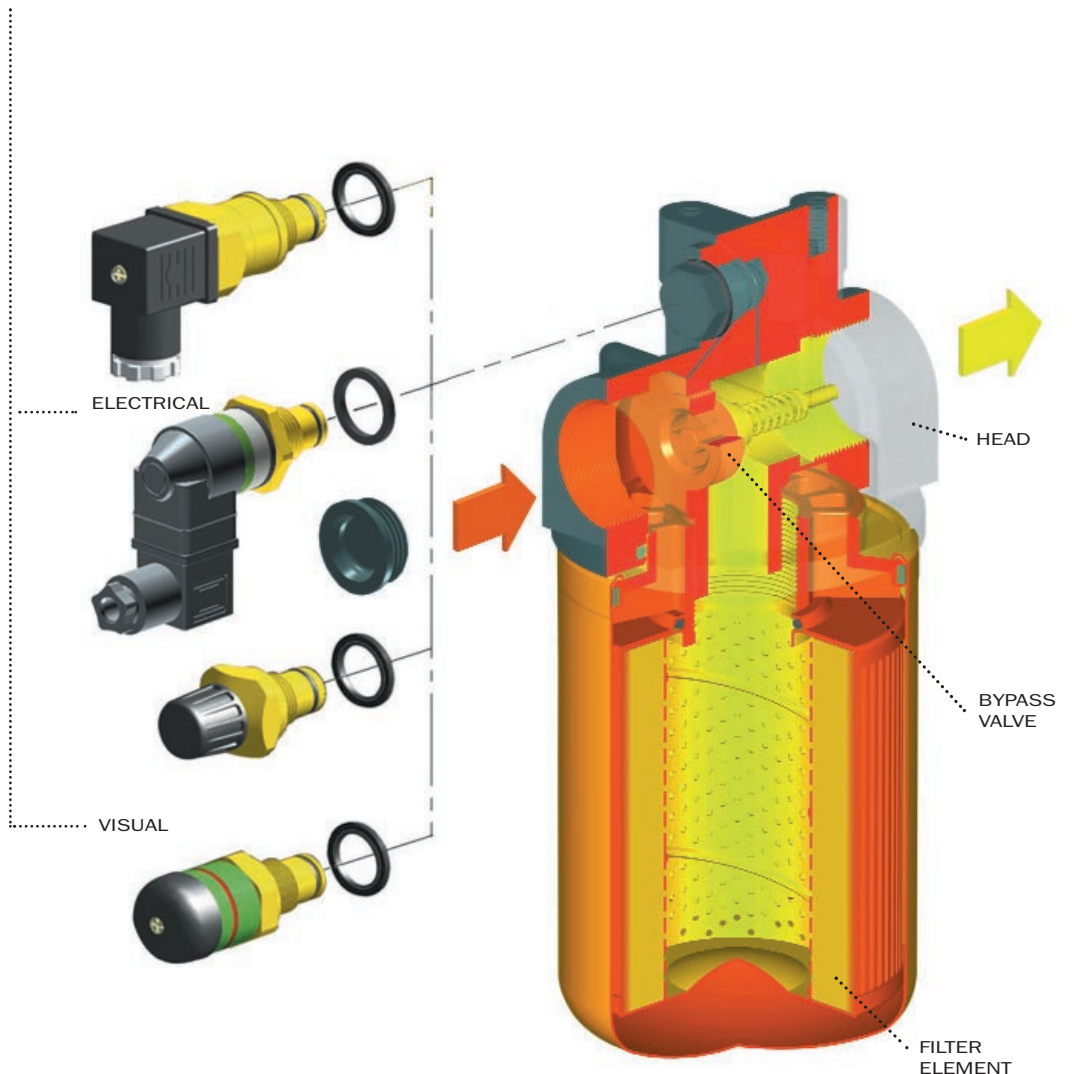

## Filter element:

### Materials

### End caps:

Galvanized steel  
Nylon (MSH 050/070)

### Support tube:

Galvanized steel

### Support frames:

Galvanized steel with an epoxy coating

### A Series

#### Inorganic microfibre

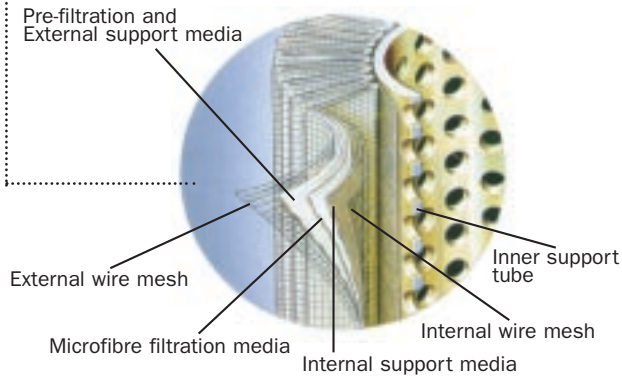

### MP Filter elements - Conform to the following ISO standards

- ISO 2941 - Verification of collapse/burst resistance.
- ISO 2942 - Verification of fabrication integrity and determination of the first bubble point.
- ISO 2943 - Verification of material compatibility with fluids.
- ISO 3723 - Method for end load test.
- ISO 3724 - Verification of flow fatigue characteristics.
- ISO 3968 - Evaluation of pressure drop versus flow characteristics.
- ISO 16889 - Multi-pass method for evaluating filtration performance.

### Element material Absolute filtration

## A Series

Inorganic microfibre with acrylic support

### Contamination retention

as per ISO 16889: Multi-pass test.

**New improved  $\beta \geq 200$  filter elements with greater efficiency and increased dirt holding capacity**

Filter elements	Dimensions for $\beta$ ( $\mu\text{m}$ ) values				Filtration ratios			$\Delta P$ (bar)
	$\beta \geq 2$ (50%)	$\beta \geq 20$ (95%)	$\beta \geq 75$ (98,7%)	$\beta \geq 200$ (99,5%)	$\beta_2$	$\beta_{10}$	$\beta_{20}$	
A03	-	2	2,4	3	20	> 10.000	> 10.000	7
A06	-	3	4,6	6	8	> 2.000	> 10.000	7
A10	3	6	7,8	10	1,5	$\geq 200$	> 10.000	7
A25	13	19	22	25	-	> 1,5	> 35	7

N.B. Other materials giving different degrees of filtration are available on request.

Type CH	050	070	100	150
A03/A06	217	450	620	800
A10/A25	217	450	620	800

Values in in<sup>2</sup>

### Filtering area Filter elements

### Element material Nominal filtration

## P Series

Resin - impregnated paper

## M Series

Square wire mesh (filtration degree is defined in microns by the maximum diameter of a sphere corresponding to the mesh size)

### Filtering area Filter elements

Type CH	050	070	100	150
P10/P25	280	560	800	100
M25	190	250	320	450
M60	190	250	320	450
M90	190	250	320	450

Values in in<sup>2</sup>

## Filter body:

### Materials

#### Head

Aluminium

#### Bypass valve

Nylon

#### Selas

A Series: Nitrile (Buna-N)

V Series: Viton

#### Indicator

Brass

### Working

#### temperature

From -13 to +230°F

For temperatures outside this range, please consult our Sales Network Organization

### Pressure filter

#### body

Maximum working pressure up to 35 bar

Fatigue test: A filter subjected to pressure impulses from 0 to 500 psi will withstand 1.000.000 cycles.

### Collapse pressure

#### filter elements

75 psi

### Bypass valve

#### Calibration pressure

Bypass valve, differential opening pressure:

35 psi ± 10%

### Types of indicators

Description:

**MSH** series filters are fitted with , differential style indicators

switching at : 30 psi ± 10%

#### Visual indicator

**V6 - Z6 Series**

switching at : 30 psi ± 10%

#### Electrical indicator

**N6 Series**

switching at : 30 psi ± 10%

#### Visual-electrical indicator

**K6\* Series**

switching at 30 psi ± 10%

\*For K visual-electrical indicator, specify the voltage (il. K61 = LED: 24 volt)

{ 1 - 24 Volt  
2 - 115 Volt  
3 - 230 Volt

# MP Filtri - Specification

## Pressure differential indicator option

### K - E - N Series

Supply voltage (50/60 Hz) (V)	Resistive load (A)	Inductive load (A)
Vca 125	5	2
Vca 250	5	2
Vcc 30	5	3
Vcc 125	0,5	0,03
Vcc 250	0,25	0,03

### CONNECTOR DIN 43650

### ELECTRICAL CONNECTION E - N SERIES

### ELECTRICAL CONNECTION K SERIES

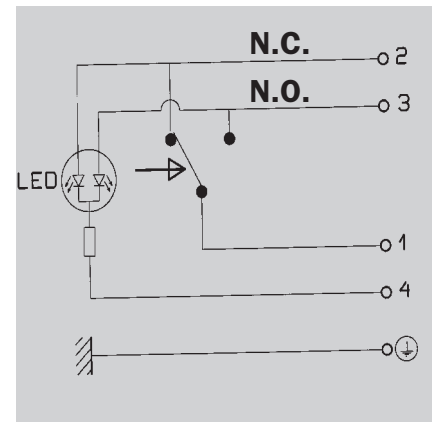
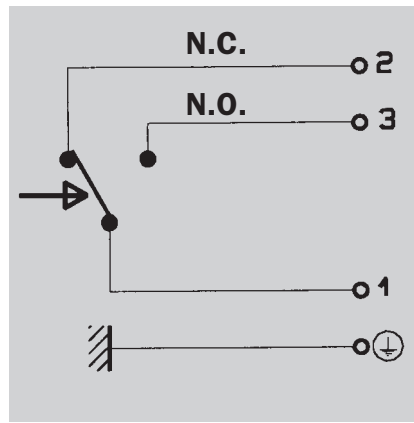
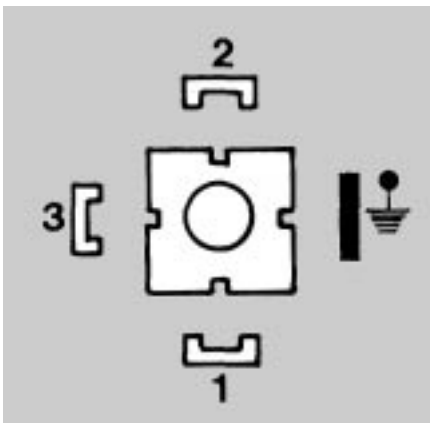

Visual V series

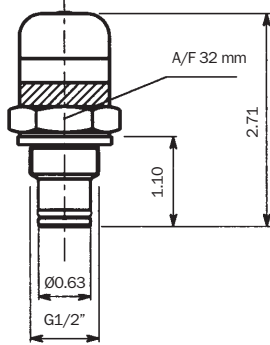

Visual Z series

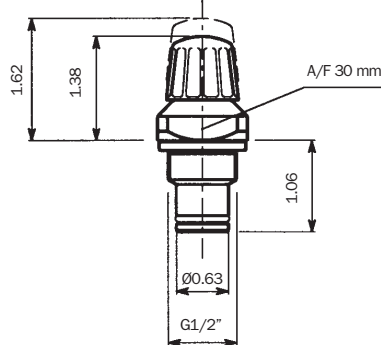

Electrical N series

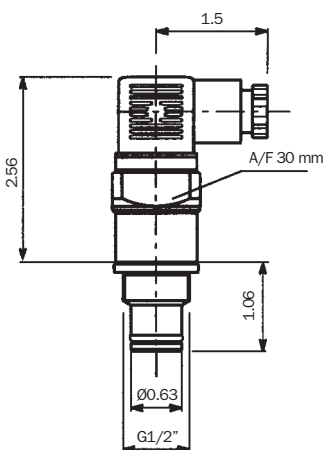

Led visual - Electrical K series

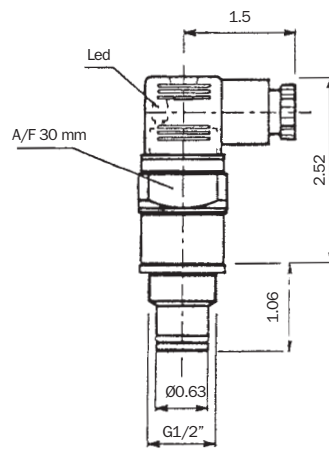

Visual - Electrical E series

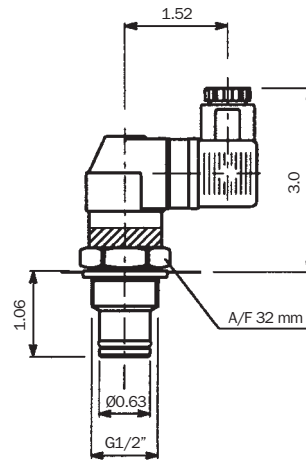

## Fluid Compatibility

### Filter head and bowls

compatible for use with:

- mineral oils (types HH-HL-HM-HR-HV-HG as per ISO 6743/4)
- water-based emulsions (types HFAE-HFAS as per ISO 6743/4)
- synthetic fluids (types HS-HFDR-HFDS-HFDU as per ISO 6743/4)
- water-glycol (types HFC as per ISO 6743/4)

### Seals

#### A Series

**Nitrile (Buna-N)** compatible with mineral oils (types HH-HL-HM-HR-HV-HG as per ISO 6743/4)

water-based emulsions (types HFAE-HFAS as per ISO 6743/4)  
water - glycol (types HFC as per ISO 6743/4)

#### V Series

**Viton** compatible with synthetic fluids (types HS-HFDR-HFDS-HFDU as per ISO 6743/4)

### Filter elements

As per ISO 2943; suitable for mineral oils (types HH-HL-HM-HR-HV-HG as per ISO 6743/4) and synthetic fluids (A and M series only) (types HS-HFDR-HFDS-HFDU as per ISO 6743/4)  
For water-based emulsions (types HFAE-HFAS as per ISO 6743/4) and fluids other than those mentioned, please consult our Sales Network Organization.

## International standards for contamination fluid control

A general (no direct) comparison between ISO 4406 and NAS 1638 is given in table below.

Contamination codes ISO 4406			Correspondent codes NAS 1638	Recommended filtration degree	Typical applications
4µm(c)	6µm(c)	14µm(c)		<i>B x ≥ 200</i>	
14	12	9	3	3	High precision and laboratory servo-systems
17	15	12	6	3-6	Robotic and servo-systems
18	16	13	7	10-12	Very sensitive - high reliability systems
20	18	15	9	12-15	Sensitive - reliable systems
21	19	16	10	15-25	General equipment of limited reliability
23	21	18	12	25-40	Low - pressure equipment not in continuous service

# Selection & installation information

## Filter elements types

### A Series

Absolute inorganic microfibre filtration media, available in 3, 6, 10 and 25 micron  
Example - **A03, A06, A10** or **A25**

### P Series

Nominal cellulose impregnated paper media, available in 10 and 25 micron.  
Example - **P10** or **P25**

### M Series

Metal mesh media, available in 25, 60, and 90 micron.  
Example - **M25, M60** or **M90**.

**Please refer to individual pressure drop curves to obtain filter assembly pressure drop information**

The following filter sizing recommendations are based using a mineral oil fluid at 150 SUS with a maximum total filter assembly (housing and filter element) pressure drop of 30% of the filter condition indicator (9 psi).

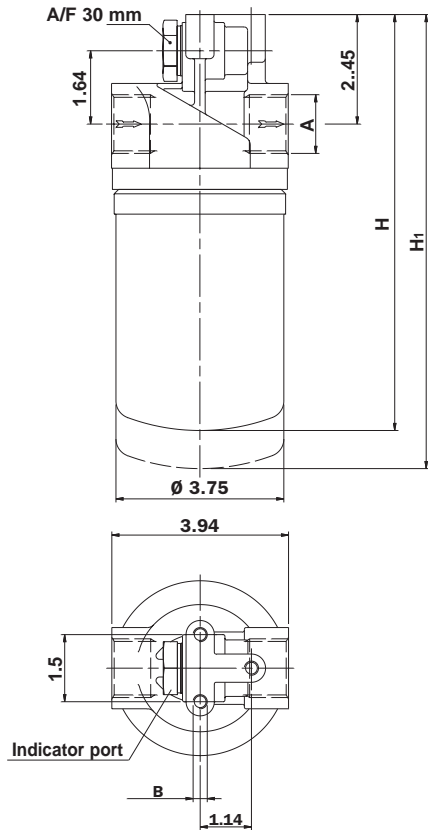

## Lengths

Type	H	H1
050	9.15	10.3
070	12.8	14.0

## Indicator

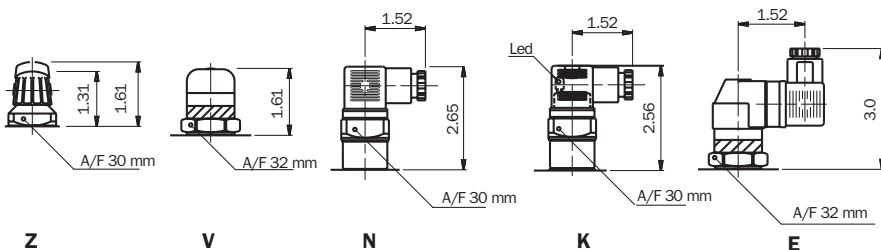

## MSH SERIES 050 - SIZES

### MSH050 - 070

Filter assembly	Flow rate gpm *	Port size BSP/NPT/SAE	Weight lbs **
A03	12	SEE TABLE BELOW	3.75
A06	13		
A10	19		
A25	27		
P10	24		
M60	32		

## MSH SERIES 070 SIZES

Filter assembly	Flow rate gpm *	Port size BSP/NPT/SAE	Weight lbs **
A03	23	SEE TABLE BELOW	4.8
A06	24		
A10	25		
A25	34		
P10	30		
M60	34		

\* Flow rates with 150 SUS fluid viscosity  
\*\* Weight including filter element

## Thread connections

Type	A	B
G1	1" BSP	M8
G2	3/4" BSP	M8
G3	1" NPT	5/16" UNC
G4	3/4" NPT	5/16" UNC
G5	SAE 16 - 1 5/16" - 12 UN	5/16" UNC
G6	SAE 12 - 1 1/16" - 12 UN	5/16" UNC

## Housing pressure drop

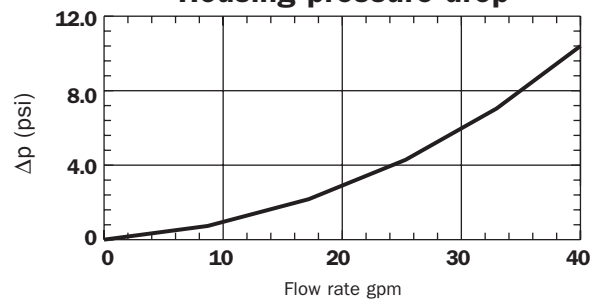

# Selection & installation information

## Filter elements types

Please refer to individual pressure drop curves to obtain filter assembly pressure drop information

The following filter sizing recommendations are based using a mineral oil fluid at 150 SUS with a maximum total filter assembly (housing and filter element) pressure drop of 30% of the filter condition indicator (9 psi).

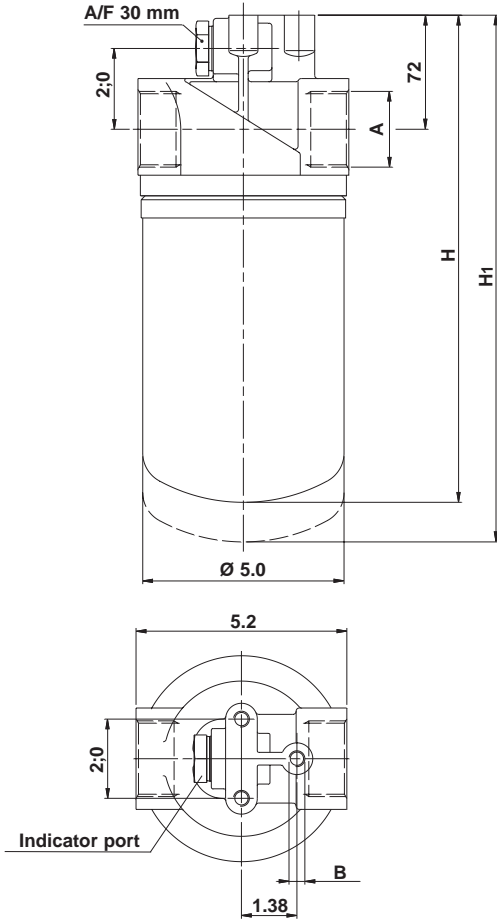

### Lengths

Type	H	H1
100	12.1	13.3
150	14.0	15.2

### Indicator

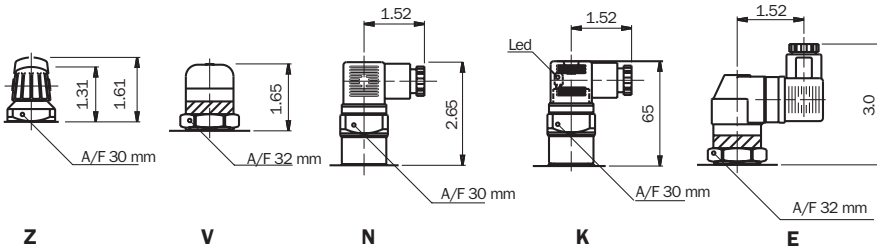

## MSH100 - 150

### MSH SERIES 100 - SIZES

Filter assembly	Flow rate gpm *	Port size BSP/NPT/SAE	Weight lbs **
A03	29	SEE TABLE BELOW	6.0
A06	32		
A10	42		
A25	56		
P10	53		
M60	66		

### MSH SERIES 150 SIZES

Filter assembly	Flow rate gpm *	Port size BSP/NPT/SAE	Weight kg **
A03	40	SEE TABLE BELOW	8.4
A06	43		
A10	47		
A25	60		
P10	70		
M60	73		

\* Flow rates with 150 SUS fluid viscosity  
\*\* Weight including filter element

### Thread connections

Type	A	B
G1	1 1/2" BSP	M10
G2	1 1/4" BSP	M10
G3	1 1/2" NPT	3/8" UNC
G4	1 1/4" NPT	3/8" UNC
G5	SAE 24 - 1 7/8" - 12 UN	3/8" UNC
G6	SAE 20 - 1 5/8" - 12 UN	3/8" UNC

### Housing pressure drop

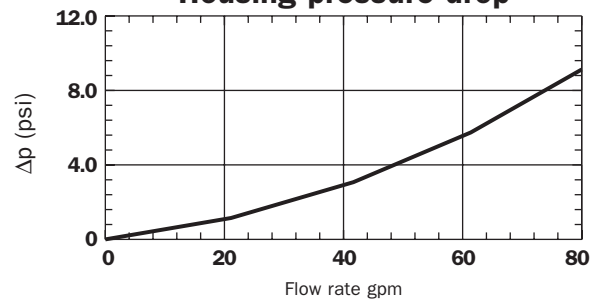

# Pressure drop information

## General

Pressure drop versus flow rate curve information for both housing and filter elements is in accordance with ISO 3968

**Filter assembly pressure drop** -  $\Delta p_{\text{Total}} = \Delta p_{\text{Housing}} + \Delta p_{\text{Filter element}}$

**Housing pressure drop** - The housing pressure drop is proportional to the fluid density

**Filter element pressure drop** - Filter element pressure drop is proportional to kinematic viscosity therefore always check the fluid operating temperature and fluid type to obtain the working viscosity according to the following formula:

$$\Delta p_1 \text{ Filter element} = (\text{working viscosity} / \text{brochure viscosity}) \times \Delta p \text{ filter element}$$

Brochure viscosity 150 SUS

## Filter assembly sizing example

- Customer requires a 48 gpm filter assembly
- Mineral oil fluid: 212 SUS
- 25 micron absolute filtration
- line application

### Selection :

- **Housing pressure drop** - MSH 100 with 48 gpm  $\Delta p = 3.9$  psi (see curve on page 8)
- **Filter element pressure drop** brochure viscosity - CH 100A25 with 48 gpm  $\Delta p = 2.9$  psi (see curve on page 10)
- **Filter element pressure drop** working viscosity - With 212 SUS  $\Delta p_1 = 2.9 \times (212/150) = 4$  psi
- **Filter assembly pressure drop**  $\Delta p_{\text{Total}} = \Delta p_{\text{Housing}} + \Delta p_1 \text{ Filter element} = 3.9 + 4.0 = 7.9$  psi\* { Acceptable pressure drop value, as per our recommendations

## Bypass valves pressure drop

The curves were obtained using a mineral oil with a density of 0,86.

The  $\Delta p$  varies proportionally to the density.

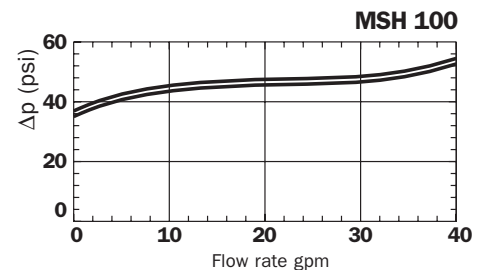
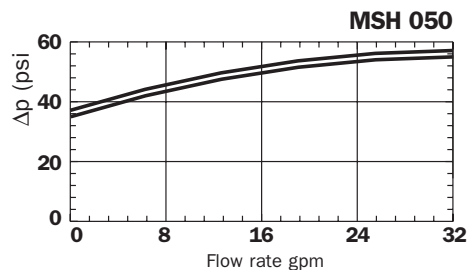

# FILTER ELEMENT

## Filter elements - P/M Series

The curves were obtained using a mineral oil with a kinematic viscosity of 150 SUS.  
The  $\Delta p$  varies proportionally to the fluid kinematic viscosity.

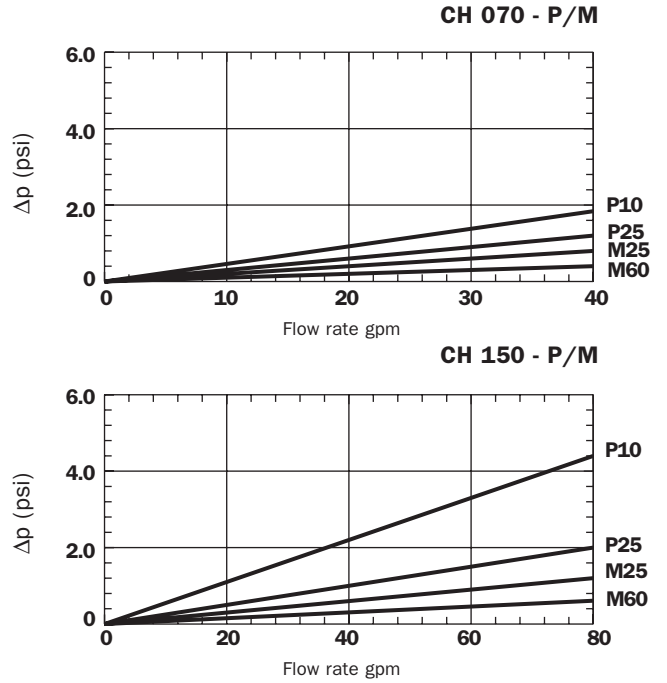
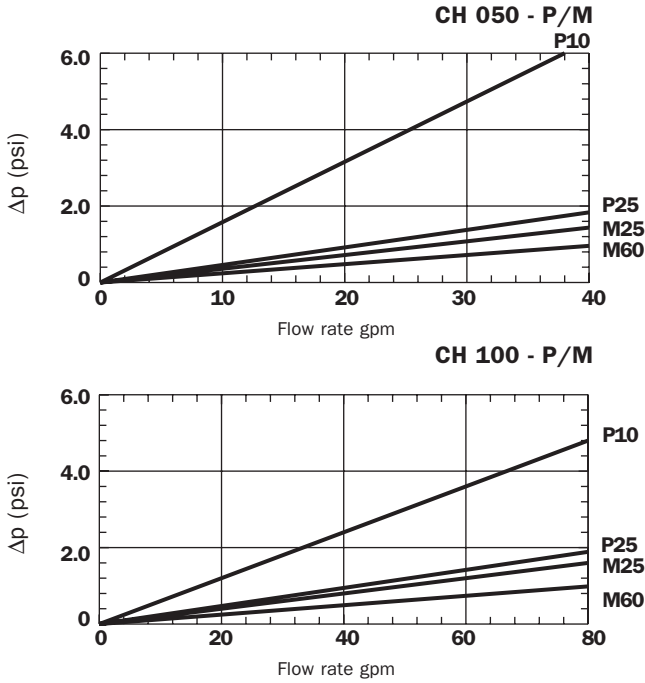

## Filter elements - A Series

The curves were obtained using a mineral oil with a kinematic viscosity of 150 SUS.  
The  $\Delta p$  varies proportionally to the fluid kinematic viscosity.

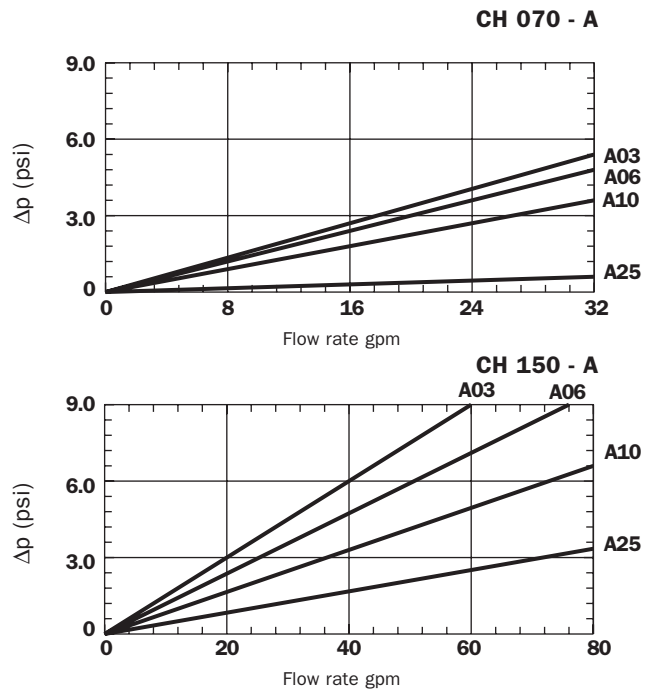
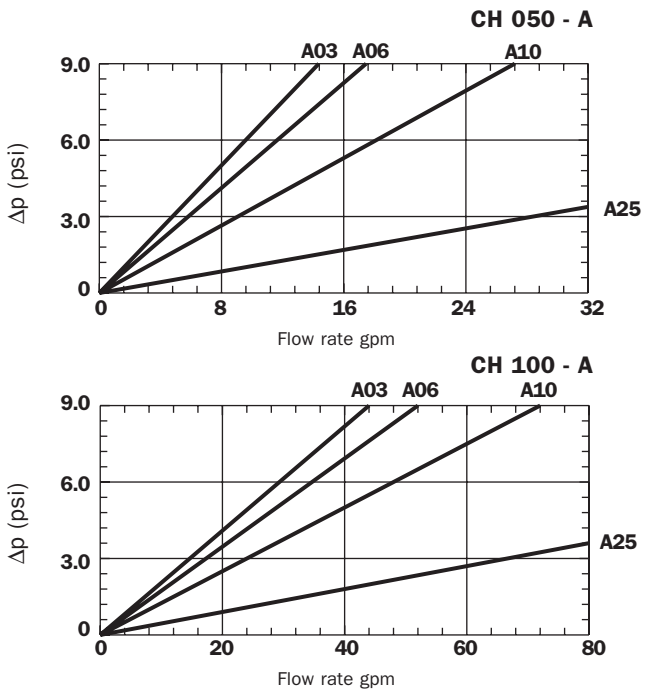

# Ordering information

## MSH

### Nominal sizes

050
070
100
150

### Filter condition indicator

S	With threaded hole only
T2	Plug for indicator port
V6	Visual 30 psi
Z6	Visual 30 psi
N6	Electrical 30 psi
E6	Visual-electrical 30 psi
K6*	Visual-Electrical 30 psi * $\left\{ \begin{array}{l} 1 - 24 \text{ Volt} \\ 2 - 115 \text{ Volt} \\ 3 - 230 \text{ Volt} \end{array} \right.$

\*For K visual-electrical indicator, specify the voltage (f.i.; K61 = LED: 24 volt)

### Bypass valve

B	With bypass 35 psi
S	Without bypass

### Filter elements M/P series

P10	Resin-impregnated paper $\beta_x \geq 2$
P25	
M25	Square wire mesh
M60	
M90	

### Filter elements A series

A03	Inorganic microfibre $\beta_x \geq 200$
A06	
A10	
A25	

### Seals

A	Nitrile (Buna - N)
V	Viton

### Port options

Type	MSH 050-070	MSH 100-150
G1	1" BSP	1 1/2" BSP
G2	3/4" BSP	1 1/4" BSP
G3	1" NPT	1 1/2" NPT
G4	3/4" NPT	1 1/4" NPT
G5	SAE 16-1 5/16"- 12 UN	SAE 24-1 7/8"- 12 UN
G6	SAE 12-1 1/16"- 12 UN	SAE 20-1 5/8"- 12 UN

## CH

# Replacement element

**MP Filtri** - Filtration products will only be guaranteed if original MP Filtri replacement elements and spares are used

Data held in this publication is given only for indicative purposes. MP Filtri reserves to introduce modifications to described items for technical or commercial reasons. Copyright reserved.